



World Leader in Lift Systems

SPOA7, SPOA9, SPO9

(300 Series Lifts)

SPOA7 Capacity 7,000 lbs.

SPOA9 Capacity 9,000 lbs.

SPO9 Capacity 9,000 lbs.

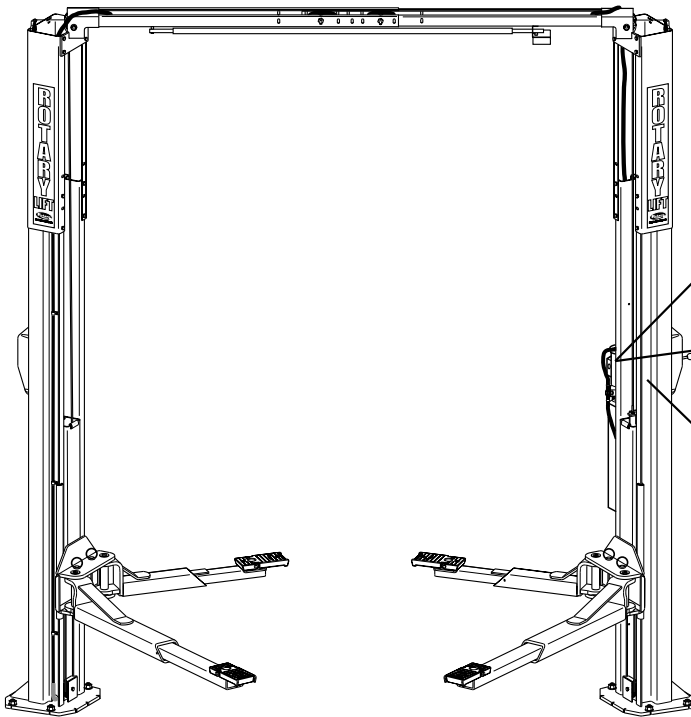

CUSTOMER		
DOVER		
SERIAL NUMBER	PART NUMBER	
DATE CODE	MODEL NUMBER	
FACTORY WIRED AT	AMPS AT MAXIMUM WORKING LOAD	RELIEF P.S.I.
Fenner Fluid Power Inc. Rockford, IL		

	PT#	N°
	PH	MAX AMB
DUTY		INS
THERMAL PROTECTION		
VOLTS		HP
AMPS		Kw
HZ	RPM	IP
	WARNING: MOTOR MUST BE GROUNDED IN ACCORDANCE WITH LOCAL AND NATIONAL ELECTRICAL CODES TO PREVENT SERIOUS ELECTRICAL SHOCKS	

	IMPORTANT
800-445-5438	DO NOT REMOVE THIS TAG
	WARRANTY IDENTIFICATION
MODEL:	
CAP. LBS:	
SERIAL NUMBER	
MANUFACTURED UNDER ONE OF THESE PATENTS	
5009287	
Rotary Lift	DOVER INDUSTRIES COMPANY Madison, IN
	MADE IN THE USA

PARTS BREAKDOWN

IMPORTANT: When ordering parts or requesting service always give exact model and power unit serial number. Model number is shown on nameplate attached to power unit column. Power unit serial number is located on side of power unit.

OWNERS RECORD
Complete information at right and keep in a safe place.

Date Installed _____

Installed in Bay # _____

Power Unit Serial # _____

Power Unit Model # _____

Lift Serial # _____

Lift Model # _____

NOTE: For replacement parts -See your nearest Rotary Parts Distributor.

PB 2-2-25-1
Rev. -- 04/12/01

1	L.H. Column Weldment	N719
2	R.H. Column Weldment	N729
3	Column Extension	
	SPOA7 & SPO9	N45
	SPOA9	N410
	EH-1 MODEL SPOA7/SPOA9/SPO9	N46
	EH-2 MODEL SPOA7/SPOA9/SPO9	N47
	EH-4 MODEL SPO9	N49
4	Carriage Yoke Weldment	N89
5	Arm Pin	FJ7838
6	3/16" x 2" Long Cotter Pin	41250
7	Hydraulic Cylinder	N342
8	Power Unit	
	SPOA7 SINGLE PHASE 60Hz	P1352
	SPOA7 THREE PHASE	P1353
	SPO9/SPOA9 SINGLE PHASE 60Hz	P1302
	SPO9/SPOA9 THREE PHASE	P1347
9	Power Unit Hose	FJ837
10	5/16"-18NC x 1-1/2" Bolt (Full Thread)	40271
11	5/16" External Tooth Lockwasher	40854
12	5/16"-18NC Hex Nut	40670
13	Actuator Pin Handle	FJ7985-1
14	Actuator Pin	N121-1
15	Retaining Pin	N119-3
16	Arm Restraint Spring	FJ7656-2
17	Bleeder Screw (Specify Manufacturer)	N/A
18	Carriage Bumper	FJ7391-2
19	120T Gear Block	FJ7749
20	Approach bumper	FJ7391-1
21	1/2"-13NC Hex Lock Nut	40703
22	Truarc #5304-75 Klipping for 3/4" Shaft	41411
23	Sheave	FJ7116-1
24	1/4"-20NC Zinc Hex Nut	40627
25	Sheave Cover	N119-1
26	1/4"-20NC x 3/8" Lg. PHMS Plated (2 pcs.)	40063
27	Slider block	FJ7360
28	3/4" Concrete Anchor	FJ7380
29	1-1/2" O.D. x .760-.770" I.D. x .045" Bushing	41388
30	1/4"-20NC x 2" HHCS	40109
31	1/4"-20NC Insert Locknut	40642
32	1/8" x 1" Lg. Cotter Pin	41200
33	Switch Bar Assembly	FJ7613-2
34	Spotting Wheel Dish Kit	FF729
35	Restraint Gear	FJ7750
36	3/8"-16 NC x 3/4" Long HHCS	40134
37	Arm Restraint Kit (1 arm)	*FJ7888
38	Overhead Hose	
	SPOA7	FJ838
	SPOA7 EH-1 MODEL	FJ840
	SPOA7 EH-2 MODEL	FJ841
	SPOA9/SPO9	FJ839
	SPOA9/SPO9 EH-1 MODEL	FJ842
	SPOA9/SPO9 EH-2 MODEL	FJ843
	SPO9 EH-4 MODEL	FJ845
39	Equalizer Cables	
	SPOA7	FJ7449
	SPOA7 EH-1 MODEL	FJ7545
	SPOA7 EH-2 MODEL	FJ7546
	SPOA9	N33
	SPOA9 EH-1 MODEL	N34
	SPOA9 EH-2 MODEL	N35
	SPO9	FJ7450
	SPO9 EH-1 MODEL	FJ7547
	SPO9 EH-2 MODEL	FJ7528
	SPO9 EH-4 MODEL	FJ7601
40	M5 x .7 x 8mm Flat Head MS	FA7152-1
41	Locking Latch Cable	FJ7594-1
	EH-1 & EH-2 for SPOA7/SPOA9/SPO9	FJ7595-1
	EH-4 for SPO9	FJ7600

42	3/8"-16NC x 1" Flanged HHCS	40144
43	3/8"-16NC Flanged Locknut	40664
44	Sheave Shaft	FJ7444-8
45	1/4"-20NC x 3/4" HHCS Grade 5	40099
46	Latch Cable Guide	N69
47	Hose Clip (4 req'd-Overhead)	FJ7206
48	#12 Type B x 1/2" Lg. Sl. HWHTS	40057
49	5/16"-18NC x 3/8" PHMS	40227
50	Branch Tee	FJ7668
51	Hose Clip (6 req'd-Column)	FJ7499
52	3/8"-16NC x 1/2" Flanged HHCS	40122
53	1/4"-20NC Flanged Locknut	40641
54	3/4" Spacer	FJ7871
55	Limit Switch Assembly	
	For units using less than or equal to 250V	N413
	For units using above 250 V	N414
56	1/4" External Tooth Lockwasher	40779
57	3/8" External Tooth Lockwasher	40845
58	Spring Pin-1/4" dia. x 1-1/2" Lg. (Stainless)	14427
59	1/4"-20NC x 1" HHCS Grade 5	40108
60	3/8"-16NC x 1-1/2" HHCS Grade 5	40200
61	3/8" Spring Washers	40818
62	Adapter Swivel Pin	FJ79-6
63	3/8" Internal Tooth Washer	40843
64	3/8"-16NC x 5/8" Lg. HHCS Grade 8	40155
65	3/32" Hog Ring for 1/2" Shaft (8 req'd)	FJ671-6
66	Adapter Pin	FJ671-3
67	High Step Adapter	FJ671-1
68	Low Step Adapter	FJ671-2
69	Limit Switch	
	For units using less than or equal to 250V	N413-1
	For units using above 250 V	FJ7979-1
70	Rear Outer Arm Weldment	
	SPOA7	N239-1
	SPOA9	N238-1
	SPO9	N241-1
71	Front Outer Arm Weldment	
	SPOA7	N240-1
	SPOA9	N237-1
	SPO9	N241-1
72	Rear Inner Arm Weldment	
	SPOA7	N239-2
	SPOA9	FJ7493-6
	SPO9	N241-2
73	Front Inner Arm Weldment	
	SPOA7	FJ7256-2
	SPOA9	FJ7491-6
	SPO9	N241-2
74	Rear Inner Arm Weldment (R/A)	
	SPOA7	N249-1
	SPOA9	N251-1
	SPO9	N252-1
75	Front Inner Arm Weldment (R/A)	
	SPOA7	N248-1
	SPOA9	N250-1
	SPO9	N252-1
76	Adapter Assembly	FJ6159
77	Rubber Pad	FJ6158-4
78	Control Box Adapter Plate	FA7132-2
79	#8-32NC x 1/2" Self Tapping Pan Head MS	FA7152-2
80	Control Panel	
	3Ø 208V/60 Hz.	FA7162
	3Ø 230V/60 Hz.	FA7163
	3Ø 460-480V/60 Hz. or 380-415V/50Hz.	FA7164
	3Ø 480V/50 Hz.	FA7165
81	L.H. Overhead Weldment	
	SPOA7 & SPOA9	N41-1
	SPO9 (Outer)	N43-1
82	R.H. Overhead Weldment	
	SPOA7 & SPOA9	N42-1
	SPO9 (Inner)	N44-1

NOTE: Standard hardware items should be purchased from local hardware source when possible.

CAUTION Care should be taken to use hardware equal to that specified in this listing. (If grade is not specified, use Grade 2 minimum.)

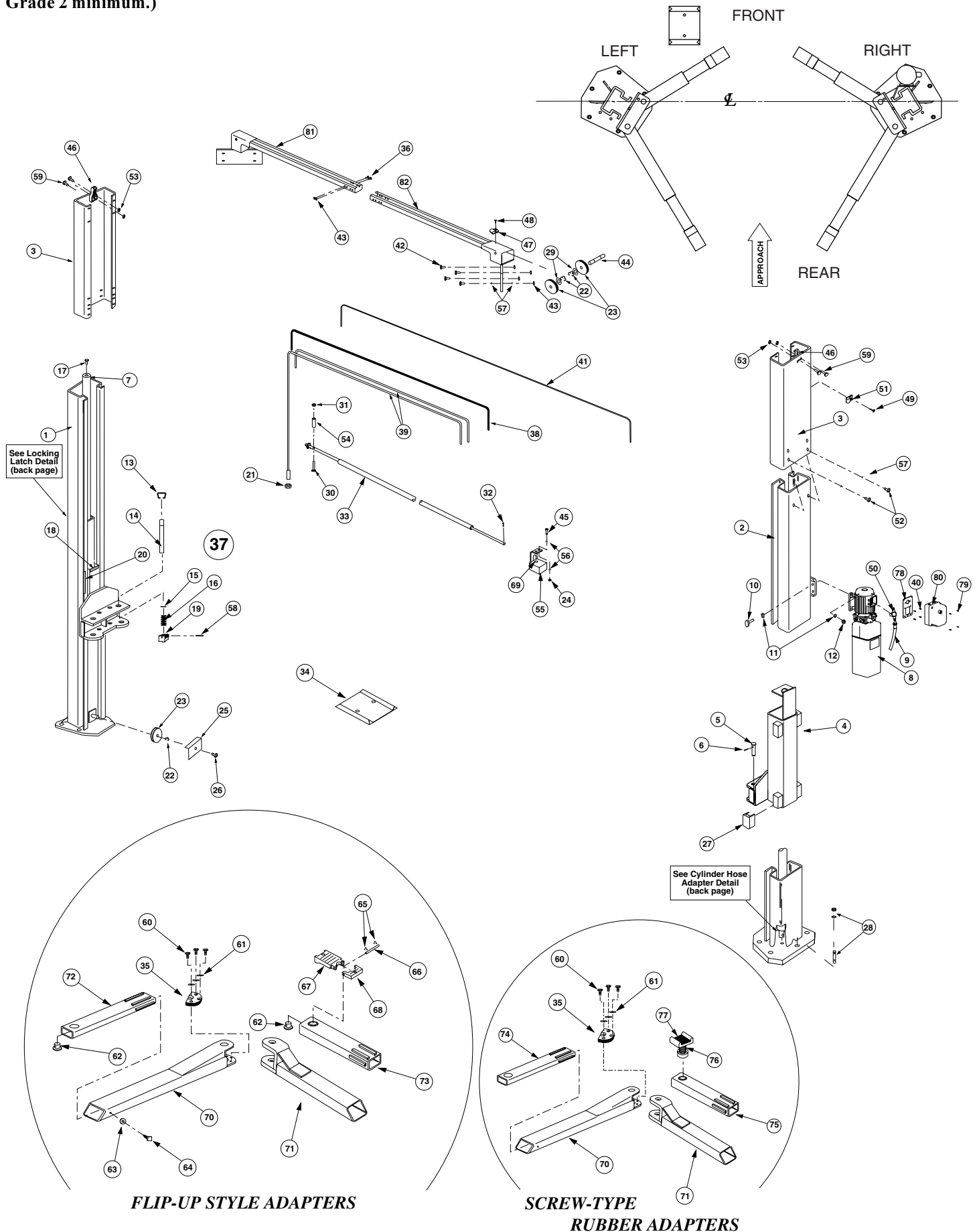

*Includes items 13, 14, 15, 16, 19, 35, 58, 60, 61

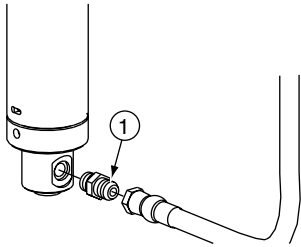

CYLINDER HOSE ADAPTER DETAIL

ITEM	DESCRIPTION	PART
1	Straight Adapter	FJ7352-3

RIGHT COLUMN

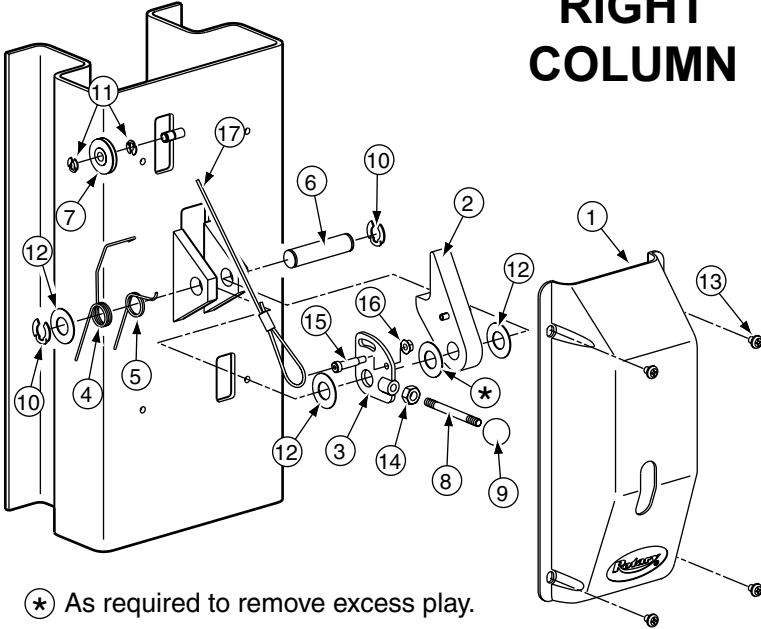

LOCKING LATCH DETAIL PARTS LIST

ITEM	DESCRIPTION	PART
1	Control Side Cover	FJ7452
2	Locking Latch Dog	FJ7382-7
3	Control Plate	FJ7594-2
4	Spring	FJ7566-10
5	Spring	FJ7382-9
6	Latch Shaft	FJ7382-34
7	Locking Latch Sheave	FJ7322
8	Handle	FJ7382-18
9	Ball Handle	FC134-91
10	Truarc Klipring #5304-75 for 3/4" Shaft	41411
11	Truarc Klipring #5304-37 for 3/8" Shaft	41410
12	1-1/2" O.D. x 3/4" I.D. x .045" Mach. Bush.	41388
13	5/16"-18NC x 3/8" Lg. PHMS	40227
14	3/8" - 16NC Hex Jam Nut	40658
15	Shoulder Bolt, 5/16"-20 NC x 1-1/4"	40220
16	Flanged Locknut, 1/4" - 20NC	41423
17	Locking Latch Cable	FJ7595-1
	EH-4 for SPO9	FJ7600

* As required to remove excess play.

LEFT COLUMN

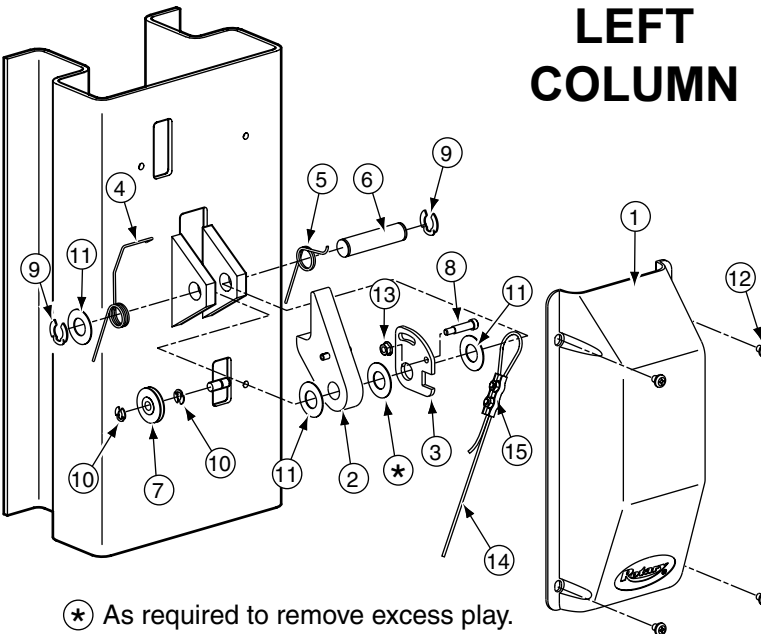

LOCKING LATCH DETAIL PARTS LIST

ITEM	DESCRIPTION	PART
1	Latch Cover	FJ7451
2	Locking Latch Dog	FJ7382-7
3	Control Plate	FJ7382-5
4	Spring	FJ7566-10
5	Spring	FJ7382-9
6	Latch Shaft	FJ7382-34
7	Locking Latch Sheave	FJ7322
8	Shoulder Bolt 5/16"-20NC x 1-1/4"	40220
9	Truarc Klipring #5304-75 for 3/4" Shaft	41411
10	Truarc Klipring #5304-37 for 3/8" Shaft	41410
11	1-1/2" O.D. x 3/4" I.D. x .045" Mach. Bush.	41388
12	5/16"-18NC x 3/8" Lg. PHMS	40227
13	Flanged Locknut, 1/4" - 20NC	41423
14	Locking Latch Cable	FJ7595-1
	EH-4 for SPO9	FJ7600
15	Latch Cable Clamp	N63-1

* As required to remove excess play.

World Headquarters
Rotary Lift
 A Dover Industries Company
 2700 Lanier Drive
 Madison, IN 47250-1753 USA
 Phone toll-free: 800.445.5438
 Phone: 812.273.1622
 Fax toll-free: 800.822.6502
 Fax: 812.273.6502
 Email: userlink@rotarylif.com
 Web site: www.rotarylif.com

Canada
 (Regional Sales Office)
Dover Corp. (Canada) LTD.
Rotary Lift Division
 130 Bridgeland Avenue Unit 210
 Toronto, Ontario
 Canada M6A 1Z4
 Phone: 416.256.4100
 Fax: 416.256.3924
 Email: canlink@rotarylifca.com

United Kingdom
 (Regional Sales Office)
Rotary Lift (UK) LTD.
 3, Fourth Avenue
 Bluebridge Industrial Estate
 Halstead, Essex CO9 2SY
 United Kingdom
 Phone: +44.178.747.7711
 Fax: +44.178.747.7720
 Email: sales@rotarylif.idps.co.uk

Austral-Asia
 (Regional Sales Office)
Rotary Lift Austral/Asia
 3A03, Block A, Phileo Damansara 1
 9, Jalan 16/11, Off Jalan Damansara
 46350 Petaling Jaya
 Selangor Darul Ehsan, Malaysia
 Phone: +60.3.7660.0285
 Fax: +60.3.7660.0289
 Email: rlim@rotarylif.com

Germany
 (European Sales Headquarters)
Rotary Lift Germany GmbH
 Lilienthalstr. 26
 64625 Bensheim
 Germany
 Phone: +49.6251.582.640
 Fax: +49.6251.582.6422
 Email: sales@rotarylif.de

Italy
 (European Manufacturing Headquarters)
Rotary Lift Europe S.r.l.
 Via Tiburtina, Km 209 & 800
 65025 Manoppello Scalo
 Italy
 Phone: +39.085.856.9058
 Fax: +39.085.856.9059
 Email: rotary.europe@rotaryeurope.com

