

Parts Breakdown

Double Section Scissor Lift

(000 Series)

Capacity 7,700 lbs (3,500 kg)
(Maximum 3,850 lbs (1,750 kg) per pad)

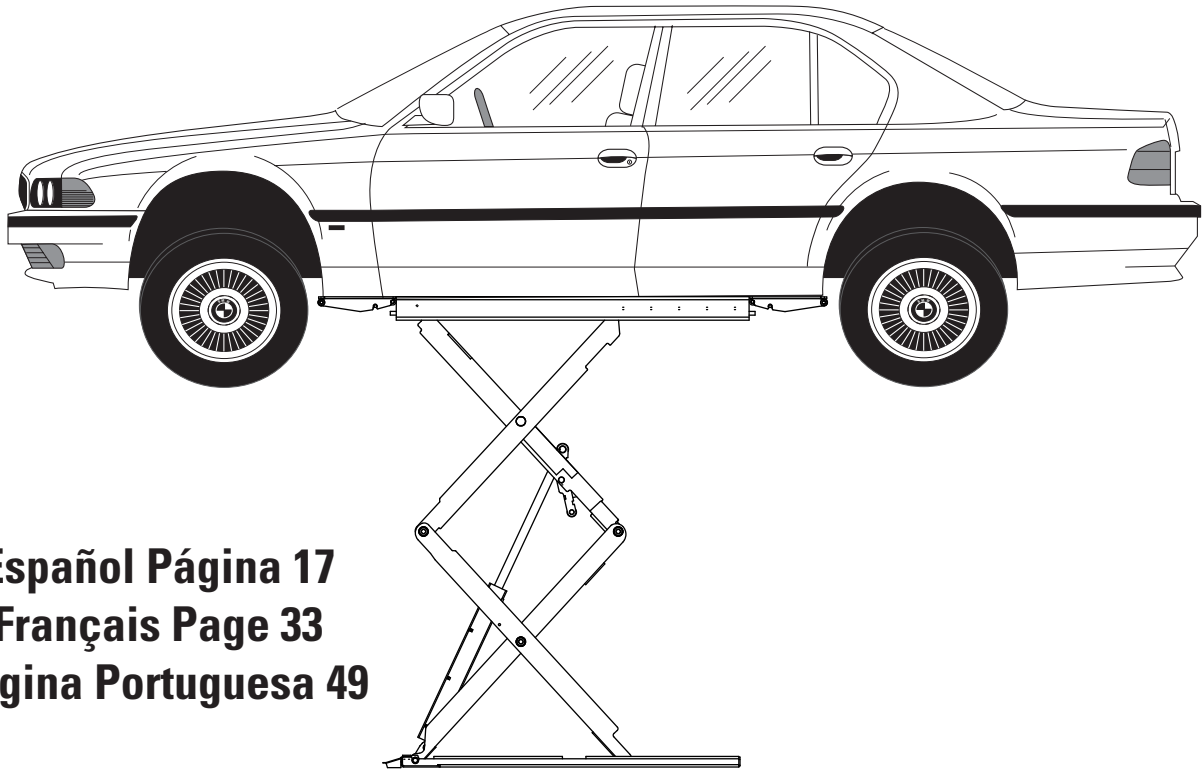

Español Página 17
Français Page 33
Página Portuguesa 49

OWNERS RECORD
Complete information
at right and keep in
a safe place.

Date Installed _____

Installed in Bay # _____

Power Unit Serial # _____

Power Unit Model # _____

Lift Serial # _____

Lift Model # _____

NOTE: For replacement parts -See your nearest Rotary Parts Distributor.

LP20632

ITEM	PART NO.	DESCRIPTION
1	B21-6X10	HEX SOCKET SET SCREW WITH FLAT HEAD M6X10
2	B22-6X10	HEX SOCKET HEAD SCREW WITH POINT HEAD M6X10
3	B26-5X10	SOCKET FLAT HEAD COUNTERSUNK MS M5X10
4	FJ2427	RUBBER BLOCK
5	30400-1025	SHIM
6	ML50-1605	LOCK RELEASE AIR CYLINDER
7	XX110001	KICKER ASSEMBLY
8	XX110003	RAMP ASSEMBLY
9	XX120001	PLATFORM WELDMENT
10	XX120002	BASE WELDMENT
11	XX120003	SCISSOR LEG WELD
12	XX120004	SCISSOR LEG WELD
13	XX120005	SCISSOR LEG WELD
14	XX120006	SCISSOR LEG WELD
16	XX120023	LIFT LOCKS WELDMENT
17	XX120024	LOCK JAW BAR WELD
18	XX130080	PIN, LONG
19	XX130081	PIN, LONG
20	XX130082	LOWER CYLINDER PIN
21	XX130086	UPPER CYLINDER PIN
22	XX140005	CYLINDER
23	XX140007	SLIDER BLOCK(LOWER)
24	XX140008	UPPER SLIDER BLOCK
25	XX140014Y	BEARING, 25 DIAM. X 25 LONG
26	XX140015Y	BEARING, 25 DIAM. X 35 LONG
27	XX140019Y	BEARING, 25 DIAM. X 50 LONG
28	XX140021	UPPER CENTER PIN
29	XX140022	LOWER CENTER PIN
30	XX140023	PIN, LONG
31	XX140024	PIN, SHORT
32	XX140025	KICKER CENTER PIN
33	XG130007	M20x1.0 SLOTTED ROUND LOCKNUT
34	XX140029	WASHER, THIN PLASTIC
35	XX140037	VELOCITY FUSE
36	FJ2428	RUBBER BLOCK
37	XX140047	PLATFORM BUMPER
38	XX140048	PLATFORM RAIL
39	XX140053Y	BEARING, 20 DIAM. X 20 LONG
40	XX140054	WASHER, THIN PLASTIC
41	XX140055	SLIDER BLOCK
42	XX140056	PIN
43	XX130214	PIN
44	B60-20	SNAP RING
45	B30-10	NUT
46	B201-10X65	HEX BOLT M10 X 65
47	B63-25	SNAP RING
48	XX140062	BEARING, 25 DIAM. X 30 LONG
49	K35-7010	Ø19 WASHER
50	XX130210	CUSHION WELDMENT
51	SB700071Y	RUBBER BLOCK
52	B41-24	Ø24 WASHER
53	B35-5	M5 NUT
54	NP945	NAMEPLATE
55	FJ1009	ANCHOR
56	XX130225	STAINLESS STEEL PLATE
57	B25-6X12	M6 X 12 SCREW

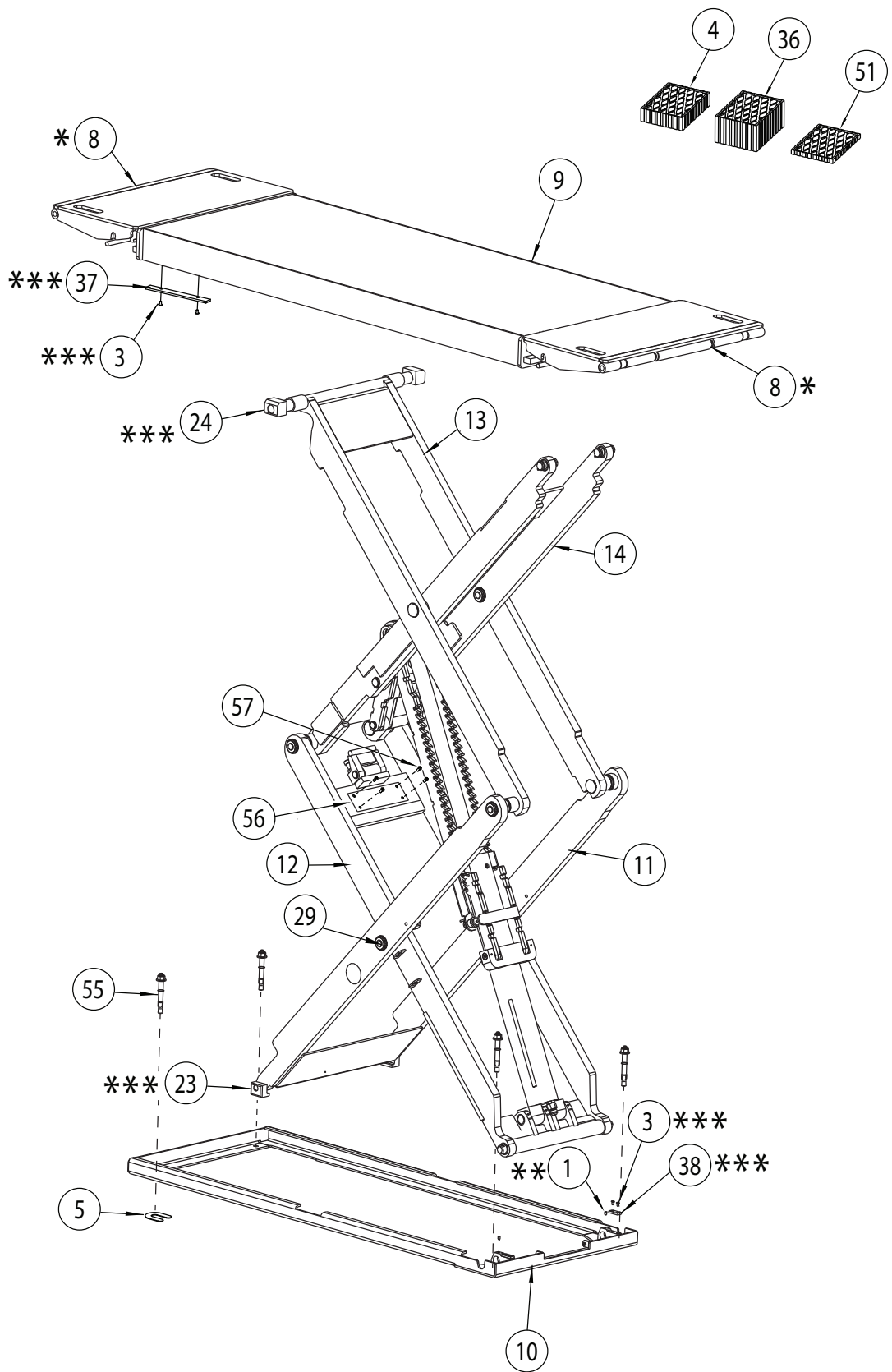

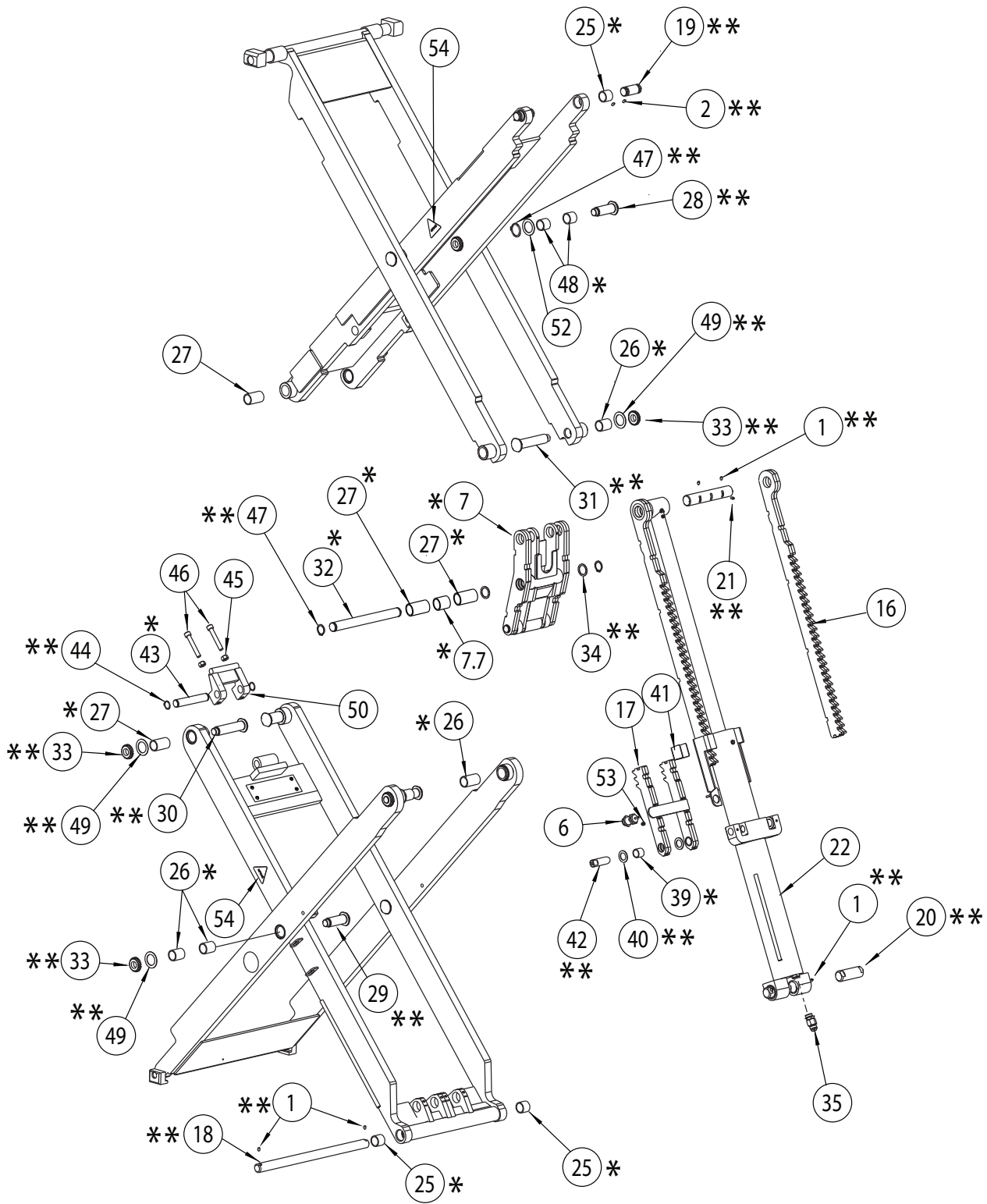

* NOTE: XX100011 REPLACEMENT BEARING KIT INCLUDES ANNOTATED BEARINGS ABOVE FOR **ONE** PLATFORM. FOR ENTIRE LIFT **TWO** BEARING KITS MUST BE ORDERED.

** NOTE: XX100007 REPLACEMENT PIN KIT INCLUDES ANNOTATED PINS ABOVE FOR **ONE** PLATFORM. FOR ENTIRE LIFT **TWO** PIN KITS MUST BE ORDERED.

*** NOTE: XX100017 REPLACEMENT SLIDER KIT INCLUDES ANNOTATED SLIDERS ABOVE FOR **BOTH** PLATFORMS (ENTIRE LIFT).

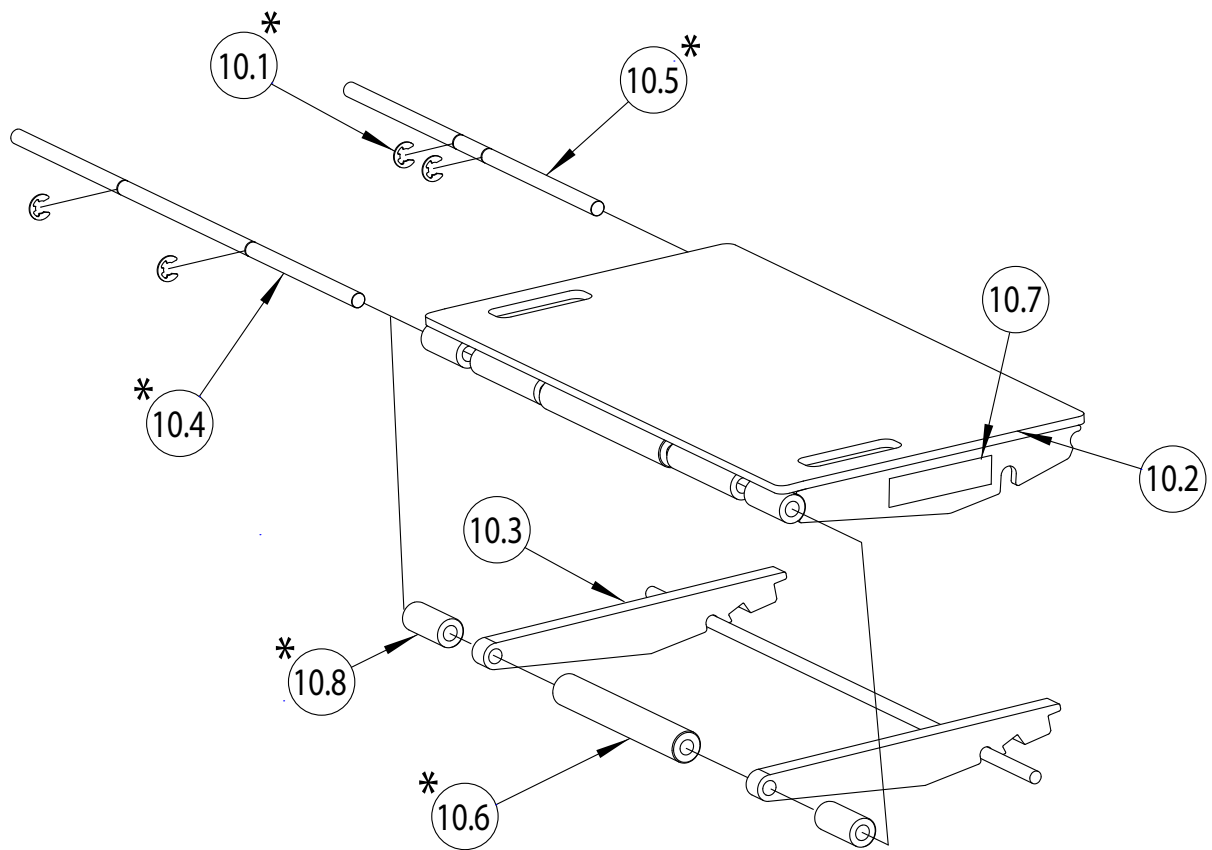

RAMP ASSEMBLY

ITEM	PART NO.	DESCRIPTION
10.1	B61-12	E-CLIP 14MM
10.2	XX120007	RAMP WELDMENT
10.3	XX120008	RAMP SUPPORT WELDMENT
10.4	XX130063	RAMP ROLLER SHAFT
10.5	XX130064	RAMP ROLLER SHAFT
10.6	XX140009	RAMP ROLLER
10.7	NP1207	NAME PLATE
10.8	XX130236	SMALL ROLLER

* NOTE: XX100010 REPLACEMENT RAMP ROLLER KIT INCLUDES ANNOTATED ROLLER AND ROLLER SHAFT PARTS FOR FOUR RAMPS.

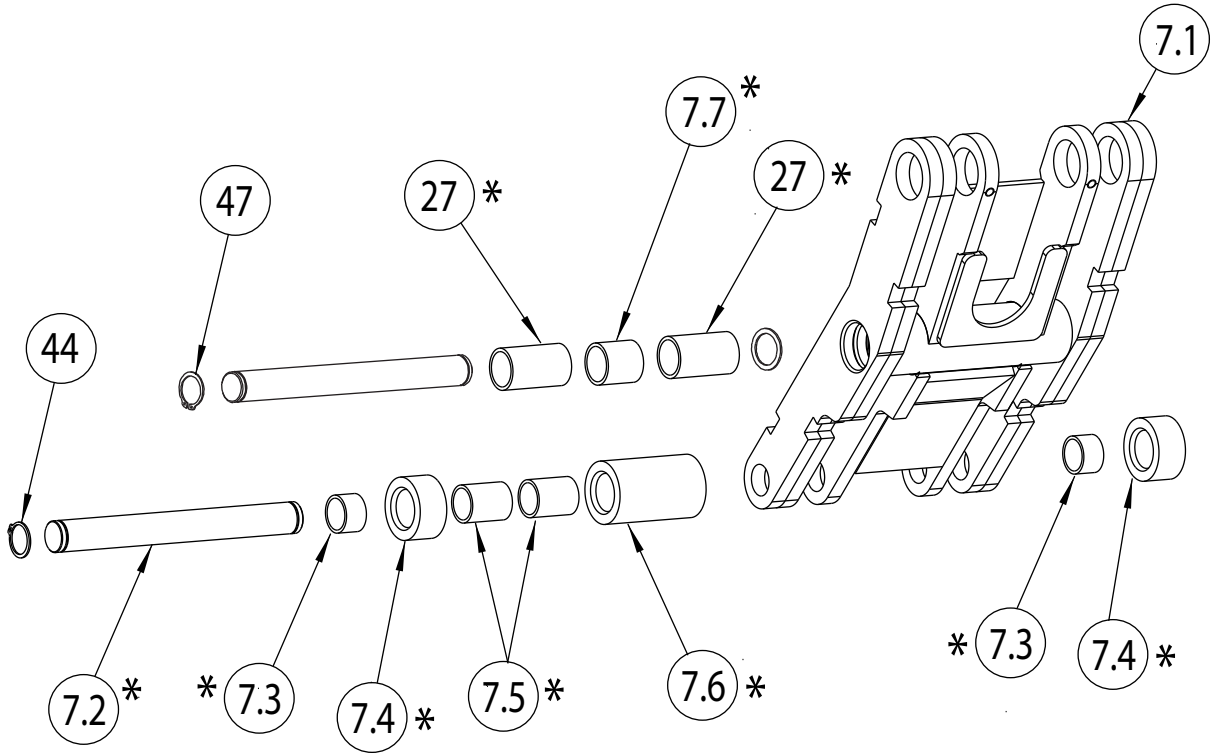

KICKER ASSEMBLY

ITEM	PART NO.	DESCRIPTION
7.1	XX120009	KICKER WELD
7.2	XX130036	ROLLER PIN
7.3	XX140060	BEARING, 20 DIAM. X 15 LONG
7.4	XX140020	ROLLER
7.5	XX140059	BEARING, 25 DIAM. X 30 LONG
7.6	XX140004	ROLLER
7.7	XX140068Y	BEARING, 25 DIAM. X 30 LONG

* NOTE: XX100008 REPLACEMENT ROLLER KIT INCLUDES ANNOTATED ROLLER SHAFT AND BEARING PARTS FOR TWO PLATFORMS.

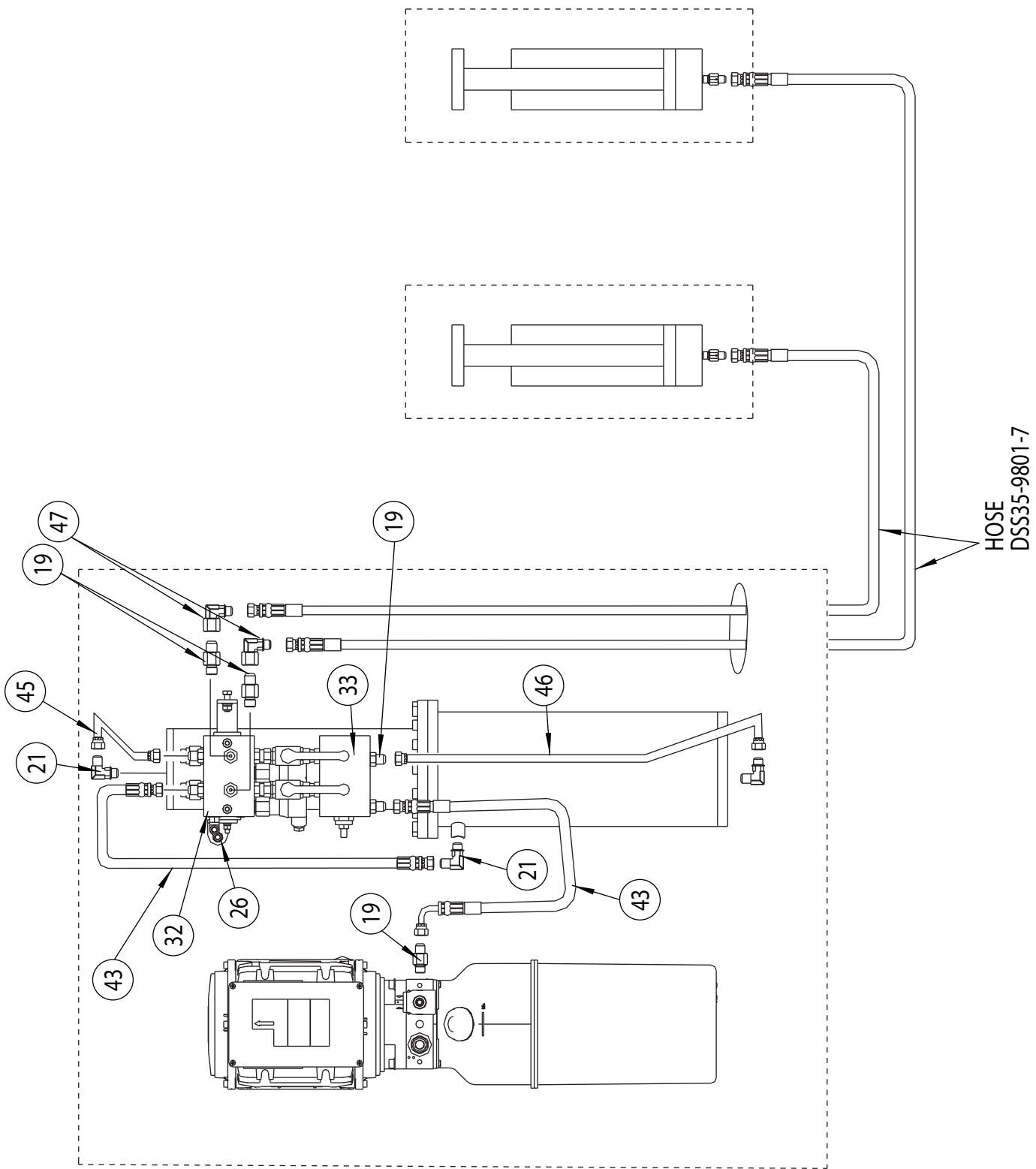

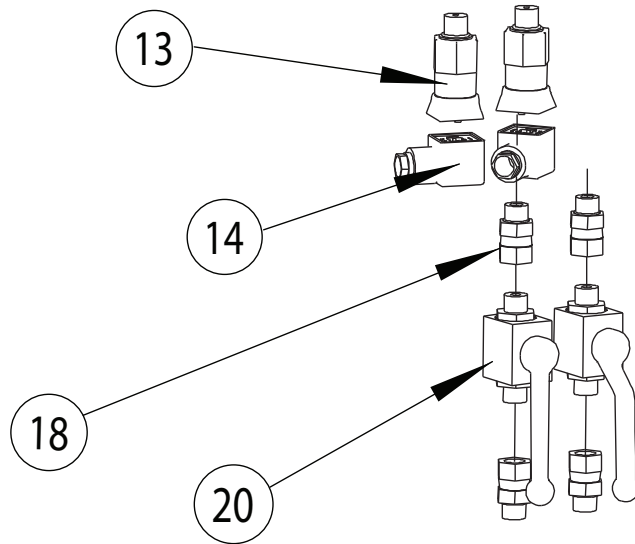

ITEM	QTY	PART NO.	DESCRIPTION
13	2	BAF-SR-65-C-H-9-UL	PRESSURE SWITCH
14	2	C18311N21	DIN CONNECTOR
18	4	DSS35-9802-1	FITTING
20	2	3288813	BALL VALVE

ITEM	PART NO.	DESCRIPTION
1	B42-8	8MM BIG WASHER
2	B10-6X12	FLANGE HEX BOLT M6X12
3	AB302	LOCK
4	B10-8X25	HEX HEAD BOLT M8X25
5	B10-6X25	HEX HEAD BOLT M6X25
6	B20-8X70	HEX SOCKET HEAD CAP SCREW M8X70
7	B30-6	HEX NUT M6
8	B30-8	HEX NUT M8
9	B40-6	LOCK WASHER 6
10	B40-8	LOCK WASHER 8
11	B41-6	FLAT WASHER 6
12	B41-8	FLAT WASHER
13	BAF-5R-6S-C-H-9-UL	PRESSURE SWITCH
14	C18311N21	DIN CONNECTOR
15	XX130195	ELECTRIC COVER
16	B23-4X6	SCREW 4X6, PHMS
17	PG135	CORD GRIP
18	DSS35-9802-1	FITTING
19	FJ7352-3	ADAPTER
20	3288813	BALL VALVE
21	SW-002	ELBOW FITTING
22	P3668	1Ø 60Hz 220V POWER UNIT
	P3671	1Ø 50Hz 220V POWER UNIT
	P3660	3Ø 50/60Hz 460V POWER UNIT
23	DQ-QJ-00053	SWITCH POWER SUPPLY (DR-100-24)
24	DQ-QJ-00056	BRIDGE RECTIFIER (KBPC2510)
25	PV-2005	POWER UNIT CONNECT ROD WITH BUMPER
26	EPC8-G02	AIR FITTING -Y
27	XX110014	CABINET, USA VERSION
28	XX130178	CABINET CYLINDER BUSHING
29	XX130179	CABINET CYLINDER BRACKET
30	XX130190	CABINET CYLINDER BRACKET
31	XX140058	MASTER CYLINDER
32	FKZJ-201C	MANIFOLD
33	FKZJ-201B	MANIFOLD
34	XX140065	LOCK RELEASE AIR VALVE
35	DQ-QJ-00038	POWER LIGHT
36	DQ-QJ-00002	RISE PUSH BUTTON (XX110018)
37	DQ-QJ-00001	DOWN PUSH BUTTON (XX110018)
38	DQ-QJ-00034	DISCONNECT SWITCH
39	DQ-QJ-00050	TERMINAL BLOCK (XX110017, XX110020)
	DQ-QJ-00055	TERMINAL BLOCK (XX110018)
40	AG-25W	LOCK NUT
41	XX100026	TRANSFORMER (XX110018)
	DQ-QJ-00035	TRANSFORMER (XX110018)
42	DQ-QJ-00005	CONTACTOR (XX110018)
43	DBS35-9801-1	HYDRAULIC HOSE
44	XX140037	VELOCITY FUSE
45	DSS35-9801-5	HYDRAULIC STEEL PIPE
46	DSS35-9801-6	HYDRAULIC STEEL PIPE
47	M130028Y	ELBOW FITTING
48	B14-3/8X70	CABINET ANCHOR
49	NA	NA
50	DQ-QJ-00052	POWER RELAY
51	DR-100-24	SWITCH POWER SUPPLY
52	KBPC2510	BRIDGE RECTIFIER
53	S130080	FILTER-REGULATOR-LUBRICATOR
54	FCS191-6	MALE CONNECTOR
55	EPL6-N02	MALE ELBOW
56	FCS185-96	MALE ELBOW
57	FC147-1	FEMALE BULKHEAD
58	DQ-QJ-00046	GROUNDING BAR

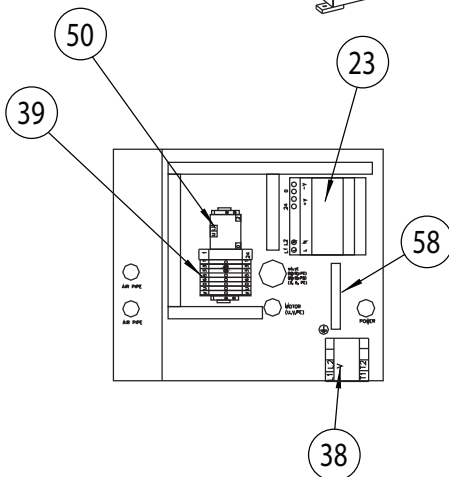
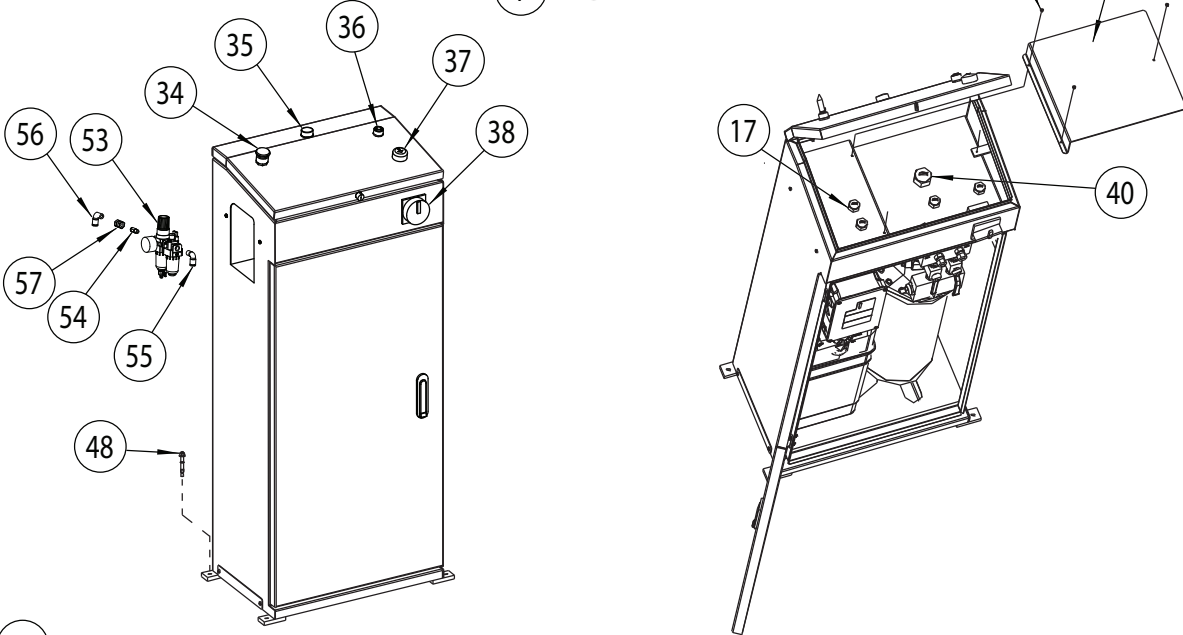
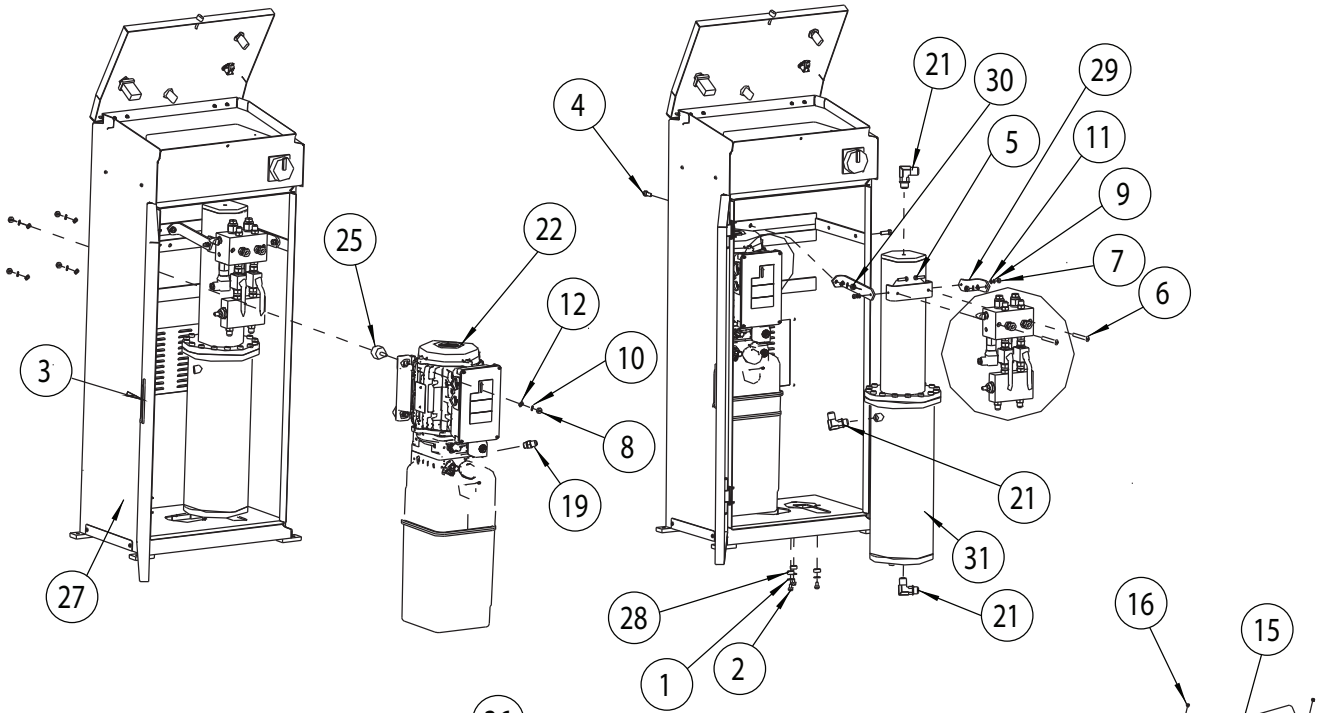

XX110017, XX110020

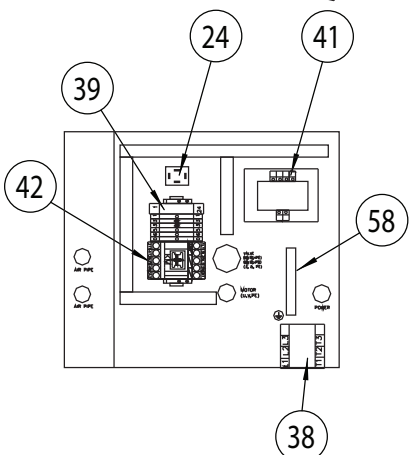

XX110018 WITH XX10026

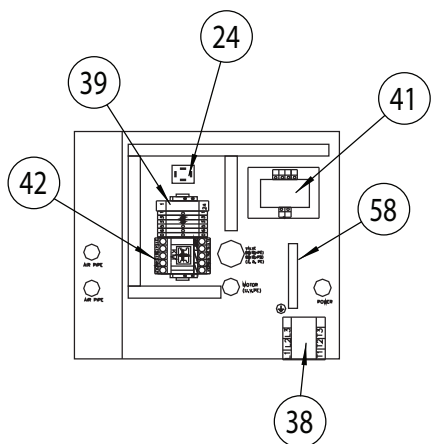

XX110018

XX100020
RECESS FLUSH
MOUNTED KIT

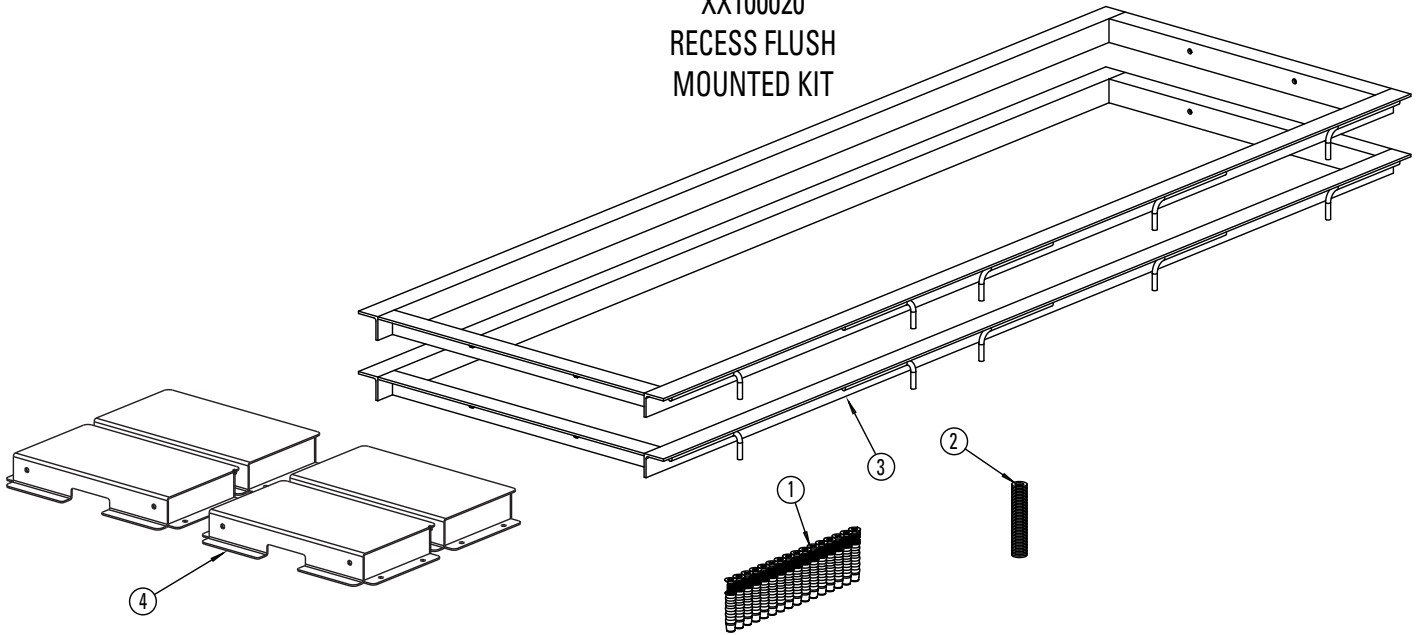

ITEM	QTY	PART NO.	DESCRIPTION
1	16	B14B-6X40	NYLON ANCHOR
2	16	B41-8	FLAT WASHER $\varnothing 8$
3	2	XX120022	RECESS WELDMENT

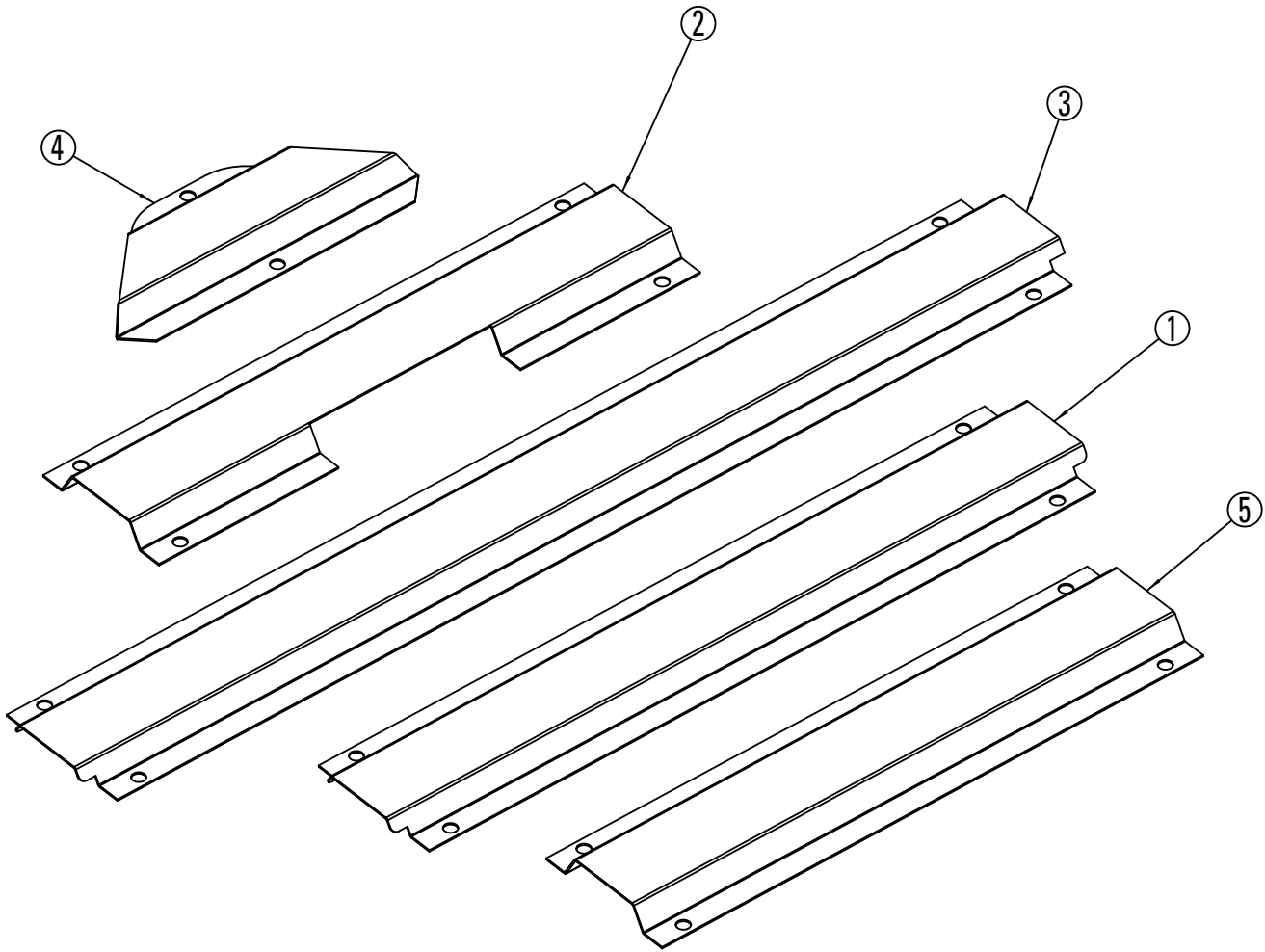

ITEM	QTY	PART NO.	DESCRIPTION
1	2	XX130091Y	HOSE COVER
2	2	XX130092Y	HOSE COVER
3	2	XX130111Y	HOSE COVER
4	1	XX130141Y	HOSE COVER 45°
5	2	XX130156Y	HOSE COVER

Notes

Notes

Notes

Vehicle Service GroupSM
2700 Lanier Drive
Madison, IN 47250, USA
1-800-640-5438
www.vsgdover.com



© **Vehicle Service GroupSM**
All Rights Reserved. Unless otherwise
indicated, **Vehicle Service GroupSM**,
and all other trademarks are property
of Dover Corporation and its affiliates.

Avería de partes

Elevador de tijera de sección doble

(Serie 000)

Capacidad 7.700 libras (3.500 kg)
(Máximo 3.850 libras (1.750 kg) por plataforma)

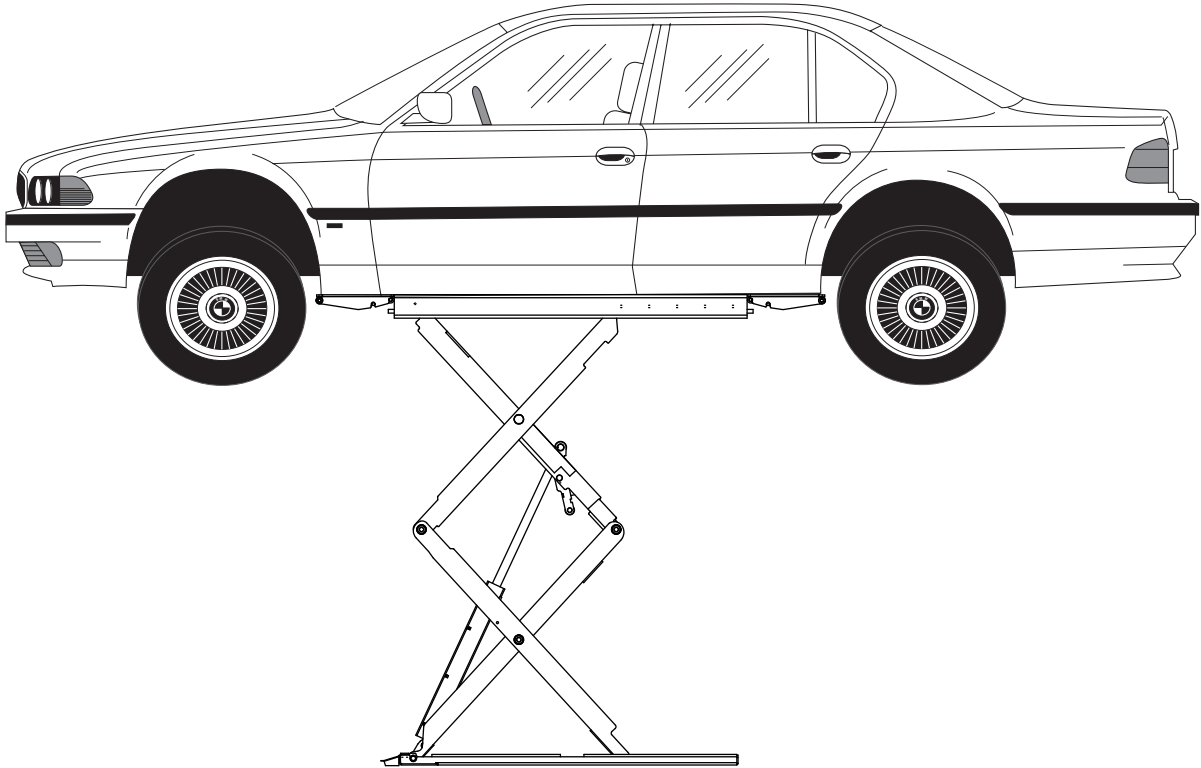

REGISTRO DEL PROPIETARIO

Complete la información
a la derecha y guárdela en
un lugar seguro.

Fecha de Instalación _____

Instalado en la Bahía No. _____

No. de Serie de la Unidad de Energía _____

No. de Modelo de la Unidad de Energía _____

No. de Serie del Elevador _____

No. de Modelo del Elevador _____

NOTA: Para piezas de repuesto: Vea a su Distribuidor de Piezas Rotary más cercano.

LP20632

ARTÍCULO	PIEZA NO.	DESCRIPCIÓN
1	B21-6X10	TORNILLO DE RETENCIÓN DE CABEZA HEXAGONAL CON CABEZA PLANA M6X10
2	B22-6X10	TORNILLO CON CABEZA HEXAGONAL CON CABEZAL EN PUNTA M6X10
3	B26-5X10	TORNILLO DE CABEZA PLANA Y CABEZAL CÓNCAVO M5X10
4	FJ2427	BLOQUE DE GOMA
5	30400-1025	SEPARADOR
6	ML50-1605	CILINDRO DE AIRE DE LIBERACIÓN DE BLOQUEO
7	XX110001	ENSAMBLAJE DE UNIÓN
8	XX110003	ENSAMBLAJE DE LA RAMPA
9	XX120001	SOLDADURA DE LA PLATAFORMA
10	XX120002	SOLDADURA DE LA BASE
11	XX120003	SOLDADURA DE LA PATA DE LA TIJERA
12	XX120004	SOLDADURA DE LA PATA DE LA TIJERA
13	XX120005	SOLDADURA DE LA PATA DE LA TIJERA
14	XX120006	SOLDADURA DE LA PATA DE LA TIJERA
16	XX120023	SOLDADURA DE BLOQUEOS DEL ELEVADOR
17	XX120024	SOLDADURA DE LA BARRA DE PINZA DE BLOQUEO
18	XX130080	CLAVIJA, LARGA
19	XX130081	CLAVIJA, LARGA
20	XX130082	CLAVIJA DEL CILINDRO INFERIOR
21	XX130086	CLAVIJA DEL CILINDRO SUPERIOR
22	XX140005	CILINDRO
23	XX140007	BLOQUE DESLIZABLE (INFERIOR)
24	XX140008	BLOQUE DESLIZABLE SUPERIOR
25	XX140014Y	RODAMIENTO, 25 DIÁM. X 25 DE LARGO
26	XX140015Y	RODAMIENTO, 25 DIÁM. X 35 DE LARGO
27	XX140019Y	RODAMIENTO, 25 DIÁM. X 50 DE LARGO
28	XX140021	CLAVIJA CENTRAL SUPERIOR
29	XX140022	CLAVIJA CENTRAL INFERIOR
30	XX140023	CLAVIJA, LARGA
31	XX140024	CLAVIJA, CORTA
32	XX140025	CLAVIJA CENTRAL DE LA UNIDAD
33	XG130007	TUERCA DE BLOQUEO REDONDA RANURADA M20X1.0
34	XX140029	ARANDELA, PLÁSTICO DELGADO
35	XX140064	FUSIBLE DE VELOCIDAD
36	FJ2428	BLOQUE DE GOMA
37	XX140047	TOPE DE PLATAFORMA
38	XX140048	RIEL DE PLATAFORMA
39	XX140053Y	RODAMIENTO, 20 DIÁM. X 20 DE LARGO
40	XX140054	ARANDELA, PLÁSTICO DELGADO
41	XX140055	BLOQUE DESLIZABLE
42	XX140056	CLAVIJA
43	XX130214	CLAVIJA
44	B60-20	ANILLO A PRESIÓN
45	B30-10	TUERCA
46	B201-10X65	PERNO HEXAGONAL M10 X 65
47	B63-25	ANILLO A PRESIÓN
48	XX140062	RODAMIENTO, 25 DIÁM. X 30 DE LARGO
49	K35-7010	ARANDELA 019
50	XX130210	SOLDADURA DE AMORTIGUACIÓN
51	SB700071Y	BLOQUE DE GOMA
52	B41-24	ARANDELA 024
53	B35-5	TUERCA M5
54	NP945	PLACA ROTULADORA
55	FJ1009	ANCLA
56	XX130225	PLACA DE ACERO INOXIDABLE
57	B25-6X12	TORNILLO M6 X 12

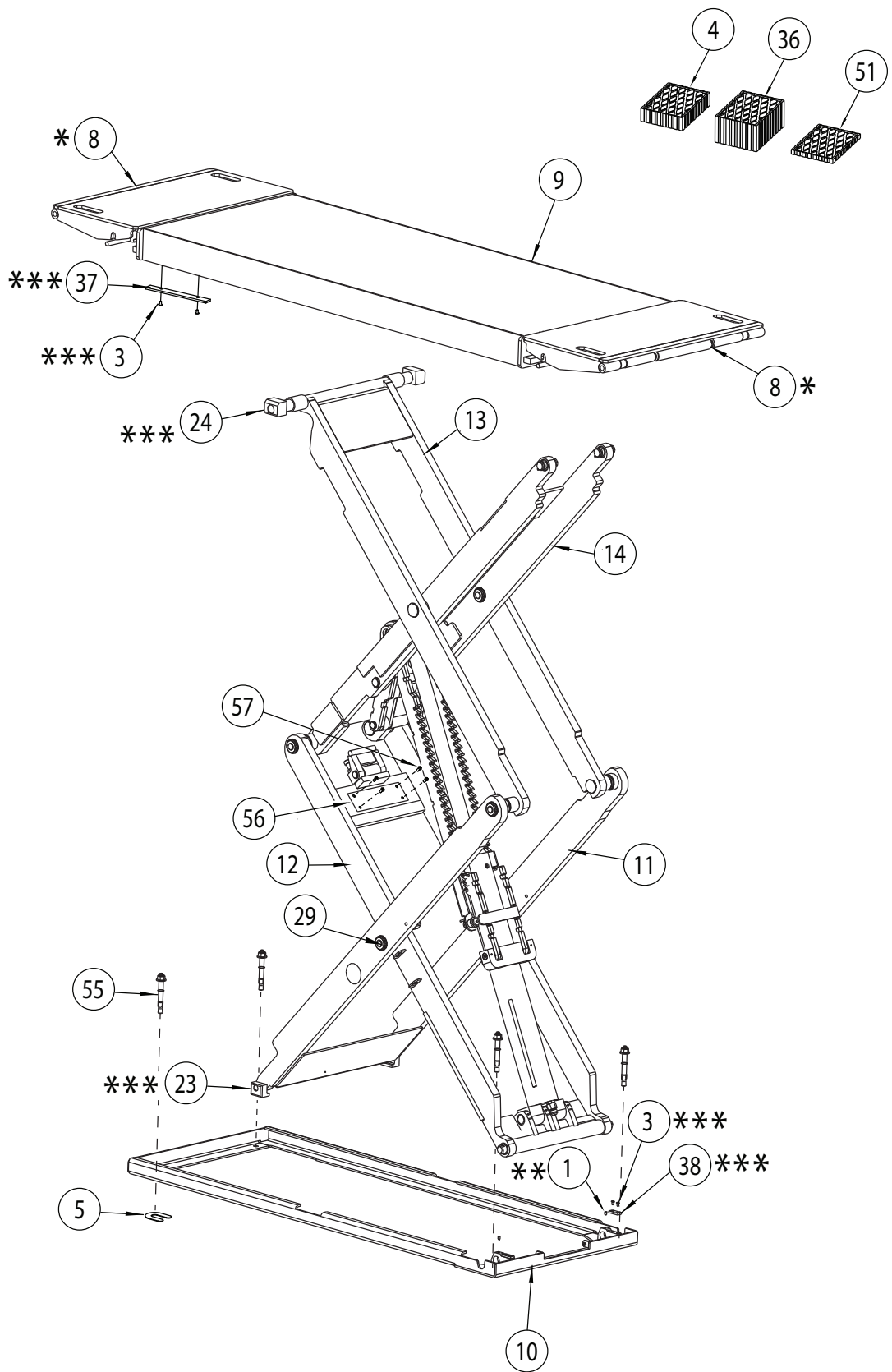

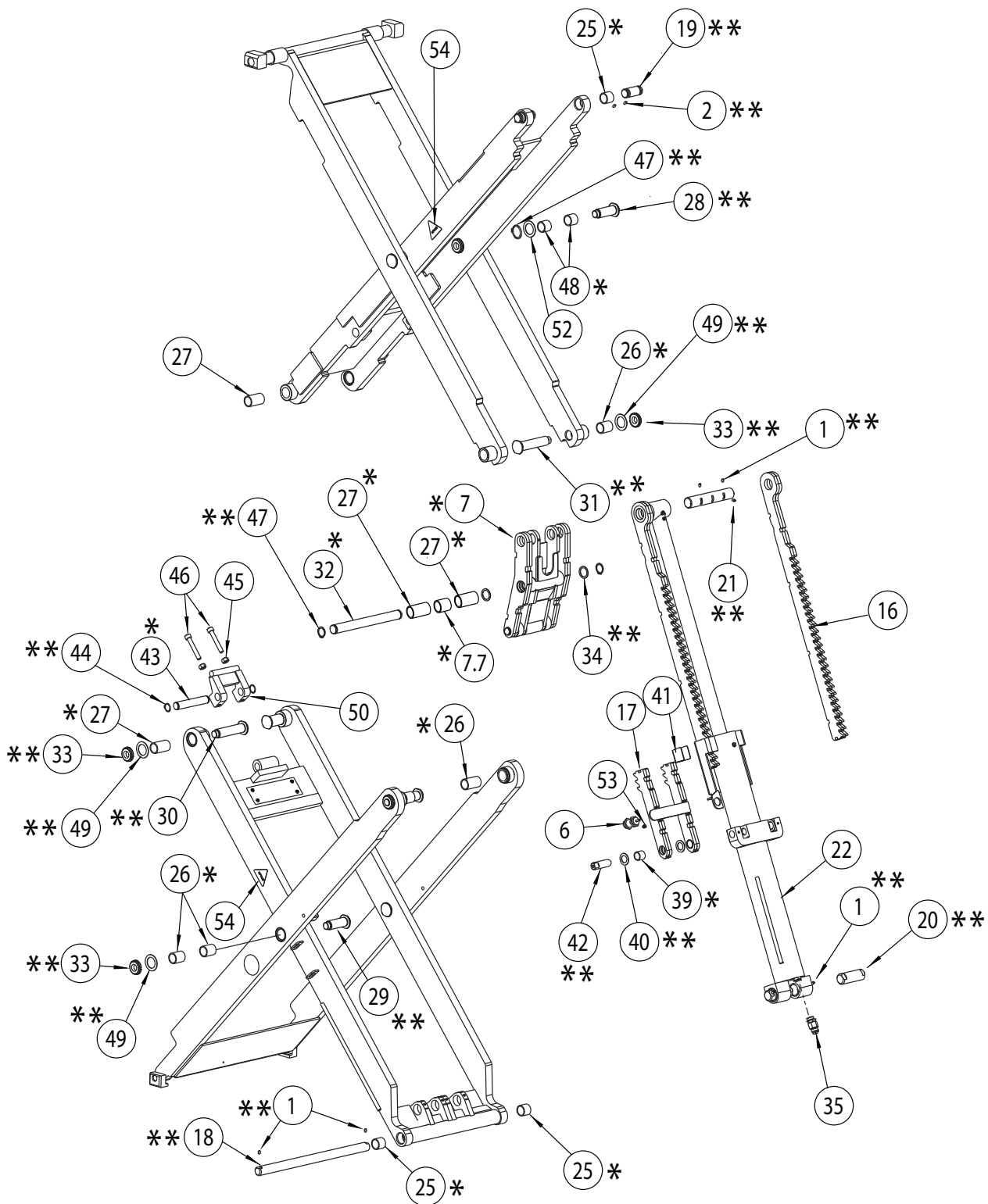

* NOTA: EL KIT DE REEMPLAZO DE RODAMIENTO XX100011 INCLUYE RODAMIENTOS ANTERIORES PARA **UNA** PLATAFORMA. PARA TODO EL ELEVADOR SE DEBEN PEDIR **DOS** KITS DE RODAMIENTOS.

** NOTA: EL KIT DE CLAVIJAS DE REEMPLAZO XX100007 INCLUYE LAS CLAVIJAS INDICADAS ANTERIORMENTE PARA **UNA** PLATAFORMA. PARA TODO EL ELEVADOR SE DEBEN PEDIR **DOS** KITS DE CLAVIJAS.

*** NOTA: EL KIT DESLIZADOR DE REEMPLAZO XX100017 INCLUYE LOS DESLIZADORES INDICADOS ANTERIORMENTE PARA LAS **DOS** PLATAFORMAS (ELEVADOR COMPLETO).

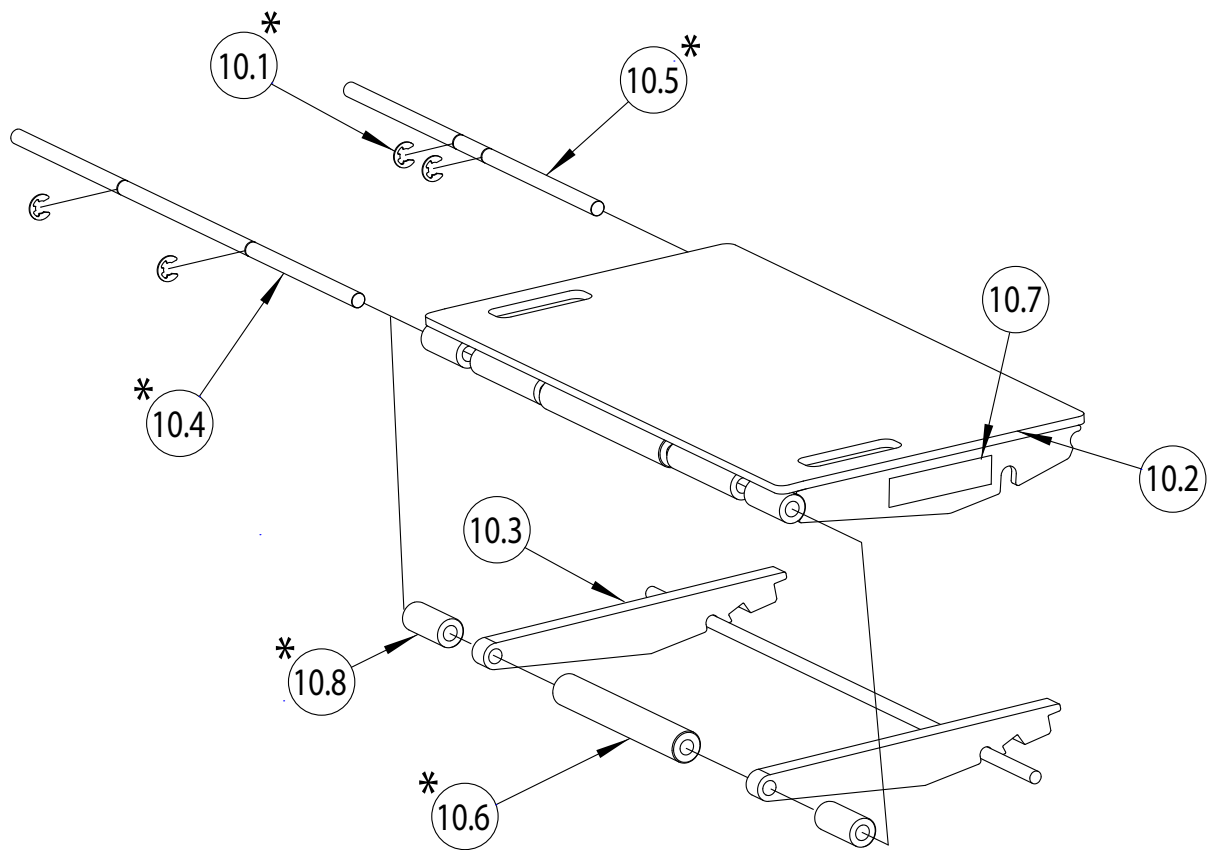

ENSAMBLAJE DE LA RAMPA

ARTÍCULO	PIEZA NO.	DESCRIPCIÓN
10.1	B61-12	GANCHO EN E 14 MM
10.2	XX120007	SOLDADURA DE RAMPA
10.3	XX120008	SOLDADURA DE SOPORTE DE LA RAMPA
10.4	XX130063	EJE DEL RODILLO DE LA RAMPA
10.5	XX130064	EJE DEL RODILLO DE LA RAMPA
10.6	XX140009	RODILLO DE LA RAMPA
10.7	NP1207	PLACA DE IDENTIFICACIÓN
10.8	XX130236	RODILLO PEQUEÑO

* NOTA: EL KIT DE RODILLO DE RAMPA DE REPUESTO XX100010 INCLUYE LAS PIEZAS DEL RODILLO Y DEL EJE DEL RODILLO INDICADAS ANTERIORMENTE PARA CUATRO RAMPAS.

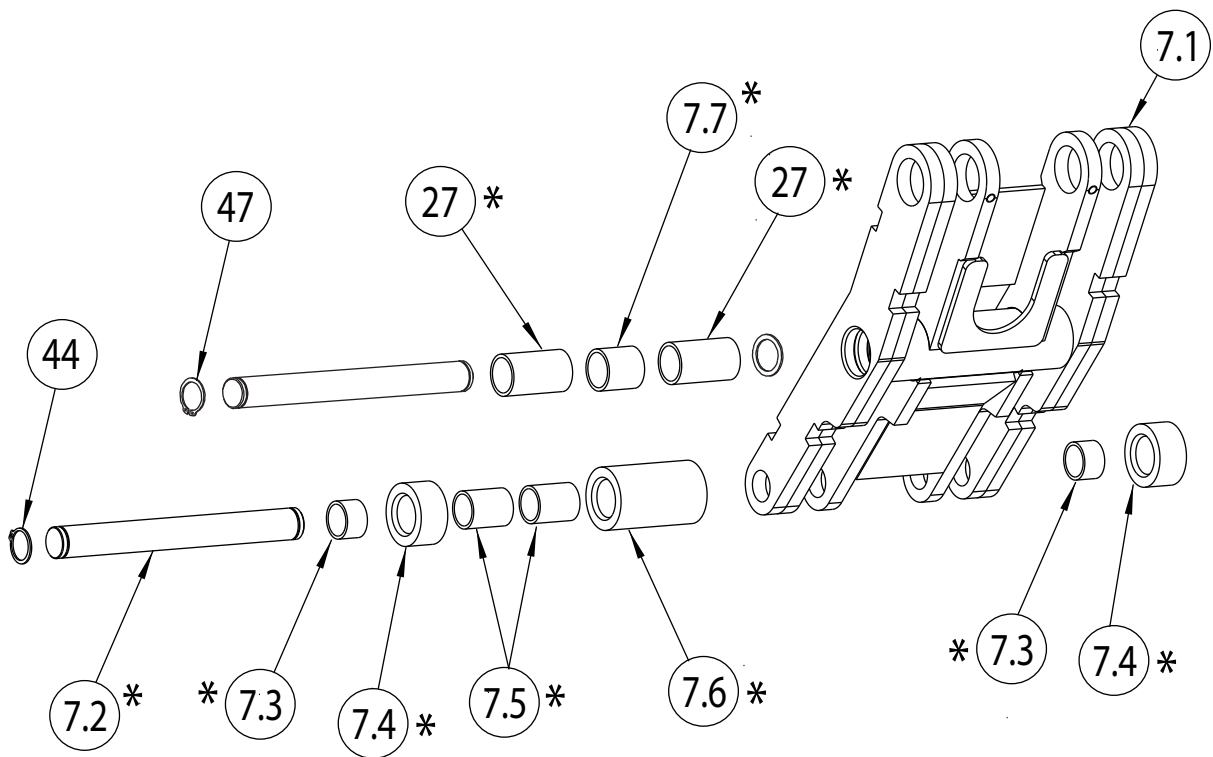

ENSAMBLAJE DE UNIÓN

ARTÍCULO	PIEZA NO.	DESCRIPCIÓN
7.1	XX120009	SOLDADURA DE UNIÓN
7.2	XX130036	CLAVIJA DEL RODILLO
7.3	XX140060	RODAMIENTO, 20 DIÁM. X 15 DE LARGO
7.4	XX140020	RODILLO
7.5	XX140059	RODAMIENTO, 25 DIÁM. X 30 DE LARGO
7.6	XX140004	RODILLO
7.7	XX140068Y	RODAMIENTO, 25 DIÁM. X 30 DE LARGO

* NOTA: EL KIT DE RODILLO DE REEMPLAZO XX100008 INCLUYE LAS PIEZAS INDICADAS DEL EJE DEL RODILLO Y RODAMIENTOS PARA DOS PLATAFORMAS.

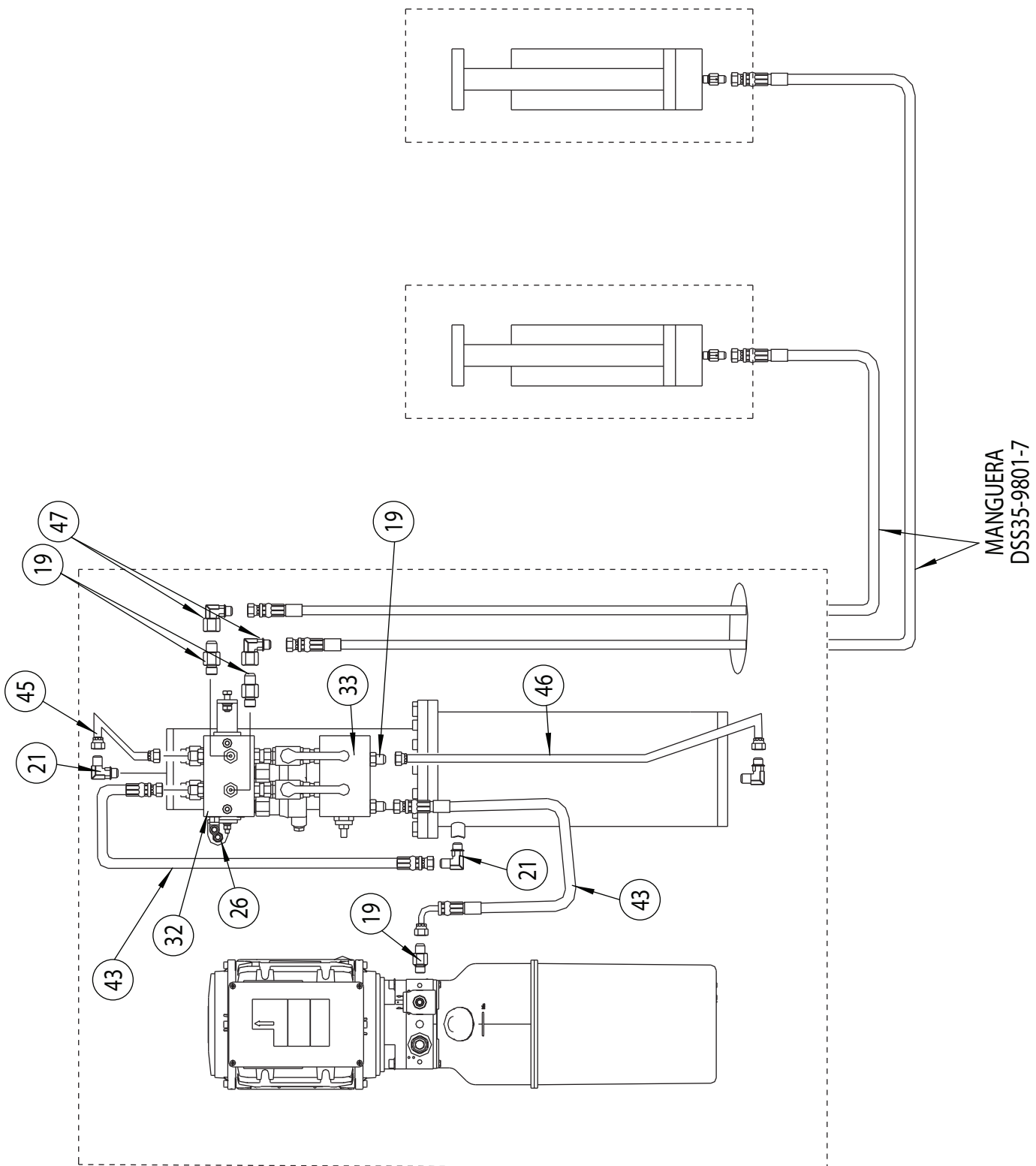

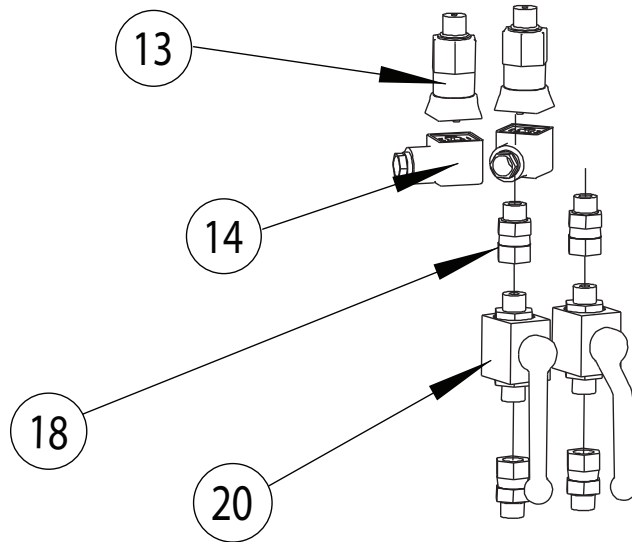

ARTÍCULO	CANT.	PIEZA NO.	DESCRIPCIÓN
13	2	BAF-SR-65-C-H-9-UL	INTERRUPTOR DE PRESIÓN
14	2	C18311N21	CONECTOR DIN
18	4	DSS35-9802-1	ACCESORIO
20	2	3288813	VÁLVULA DE BOLA

ARTÍCULO	PIEZA NO.	DESCRIPCIÓN
1	B42-8	ARANDELA GRANDE DE 8 MM
2	B10-6X12	PERNO HEXAGONAL DE BRIDA M6X12
3	AB302	BLOQUEO
4	B10-8X25	PERNO DE CABEZA HEXAGONAL M8X25
5	B10-6X25	PERNO DE CABEZA HEXAGONAL M6X25
6	B20-8X70	TORNILLO DE CABEZA CIEGA HEXAGONAL M8X70
7	B30-6	TUERCA HEXAGONAL M6
8	B30-8	TUERCA HEXAGONAL M8
9	B40-6	ARANDELA DE BLOQUEO 6
10	B40-8	ARANDELA DE BLOQUEO 8
11	B41-6	ARANDELA PLANA 6
12	B41-8	ARANDELA PLANA
13	BAF-5R-6S-C-H-9-UL	INTERRUPTOR DE PRESIÓN
14	C18311N21	CONECTOR DIN
15	XX130195	CUBIERTA ELÉCTRICA
16	B23-4X6	TORNILLO 4X6, PHMS
17	PG135	ASEGURADOR DE CABLE
18	DSS35-9802-1	ACCESORIO
19	FJ7352-3	ADAPTADOR
20	3288813	VÁLVULA DE BOLA
21	SW-002	ACCESORIO DE CODO
22	P3668	10 UNIDADES DE POTENCIA DE 60Hz 220V
	P3671	10 UNIDADES DE POTENCIA DE 50Hz 220V
	P3660	30 UNIDADES DE POTENCIA DE 50/60Hz 460V
23	DQ-QJ-00053	FUENTE DE ALIMENTACIÓN DEL INTERRUPTOR (DR-100-24)
24	DQ-QJ-00056	RECTIFICADOR DE PUENTE (KBPC2510)
25	PV-2005	VARILLA DE CONEXIÓN DE LA UNIDAD DE POTENCIA CON TOPE
26	EPC8-G02	ACCESORIO DE AIRE - Y
27	XX110014	GABINETE, VERSIÓN PARA EE. UU.
28	XX130178	COJINETE DEL CILINDRO DEL GABINETE
29	XX130179	SOPORTE DEL CILINDRO DEL GABINETE
30	XX130190	SOPORTE DEL CILINDRO DEL GABINETE
31	XX140058	CILINDRO MAESTRO
32	FKZJ-201C	COLECTOR
33	FKZJ-201B	COLECTOR
34	XX140065	VÁLVULA DE AIRE DE LIBERACIÓN DE BLOQUEO
35	DQ-QJ-00038	LUZ DE ENCENDIDO
36	DQ-QJ-00002	BOTÓN DE ELEVACIÓN (XX110018)
37	DQ-QJ-00001	BOTÓN DE DESCENSO (XX110018)
38	DQ-QJ-00034	INTERRUPTOR DE DESCONEXIÓN
39	DQ-QJ-00050	BLOQUE DE TERMINALES (XX110017, XX110020)
	DQ-QJ-00055	BLOQUE DE TERMINALES (XX110018)
40	AG-25W	TUERCA DE BLOQUEO
41	XX100026	TRANSFORMADOR (XX110018)
	DQ-QJ-00035	TRANSFORMADOR (XX110018)
42	DQ-QJ-00005	CONTACTOR (XX110018)
43	DBS35-9801-1	MANGUERA HIDRÁULICA
44	XX140037	FUSIBLE DE VELOCIDAD
45	DSS35-9801	TUBERÍA HIDRÁULICA DE ACERO
46	DSS35-9801	TUBERÍA HIDRÁULICA DE ACERO
47	M130028Y	ACCESORIO DE CODO
48	B14-3/8X70	ANCLA DEL GABINETE
49	NA	NA
50	DQ-QJ-00052	RELÉ DE CORRIENTE
51	DR-100-24	FUENTE DE ALIMENTACIÓN DEL INTERRUPTOR
52	KBPC2510	RECTIFICADOR DE PUENTE
53	S130080	FILTRO-REGULADOR-LUBRICADOR
54	FCS191-6	CONECTOR MACHO
55	EPL6-N02	CODO MACHO
56	FCS185-96	CODO MACHO
57	FC147-1	CABEZAL HEMBRA
58	DQ-QJ-00046	BARRA A TIERRA

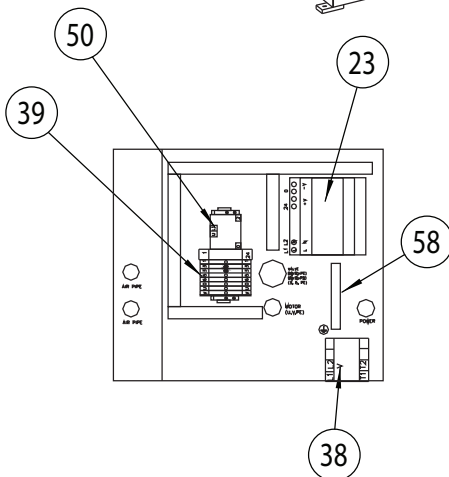
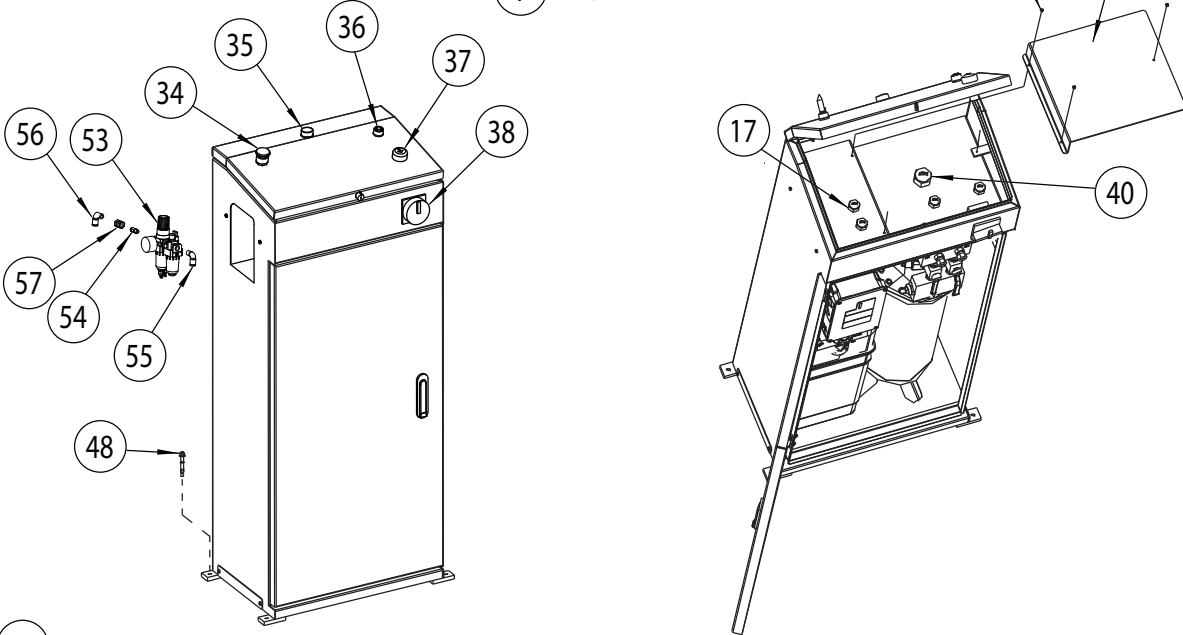
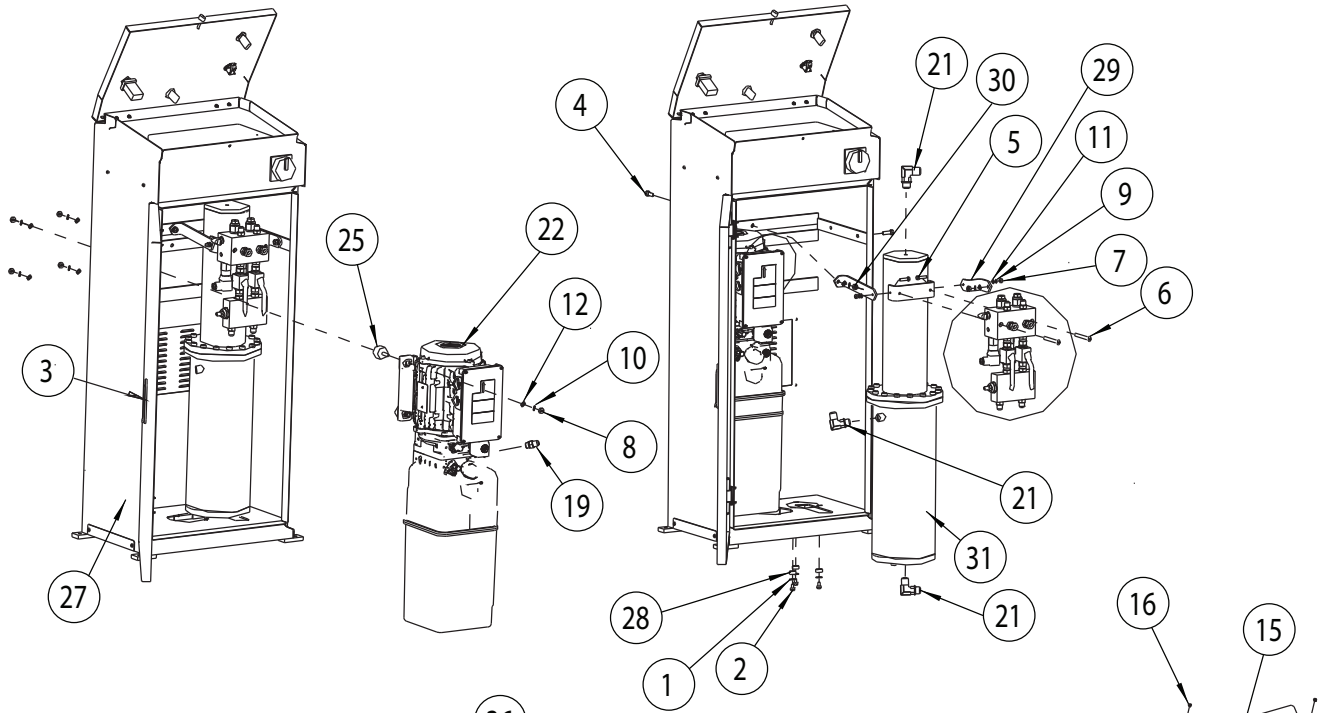

XX110017, XX110020

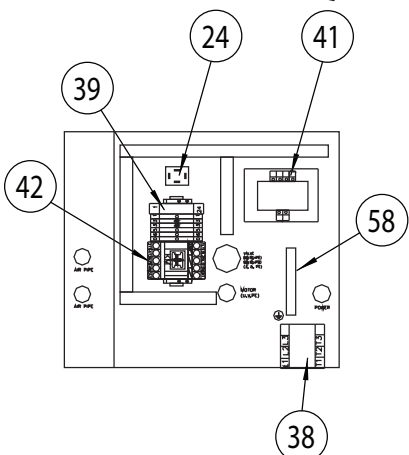

XX110018 WITH XX100026

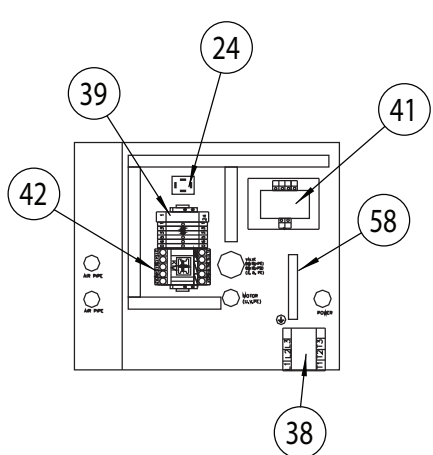

XX110018

XXI00020
KIT DE MONTAJE AL
RAS EMPOTRADO

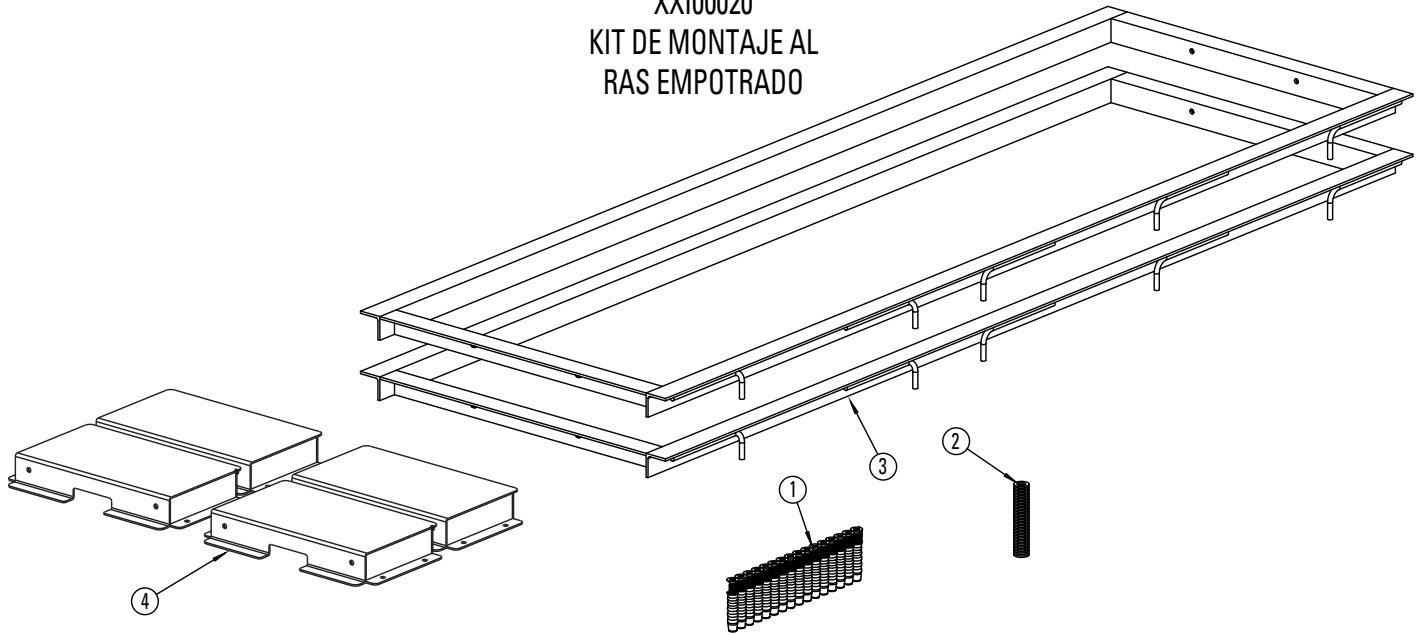

ARTÍCULO	CANT.	PIEZA NO.	DESCRIPCIÓN
1	16	B14B-6X40	ANCLA DE NAILON
2	16	B41-8	ARANDELA PLANA 08
3	2	XX120022	SOLDADURA EMPOTRADA

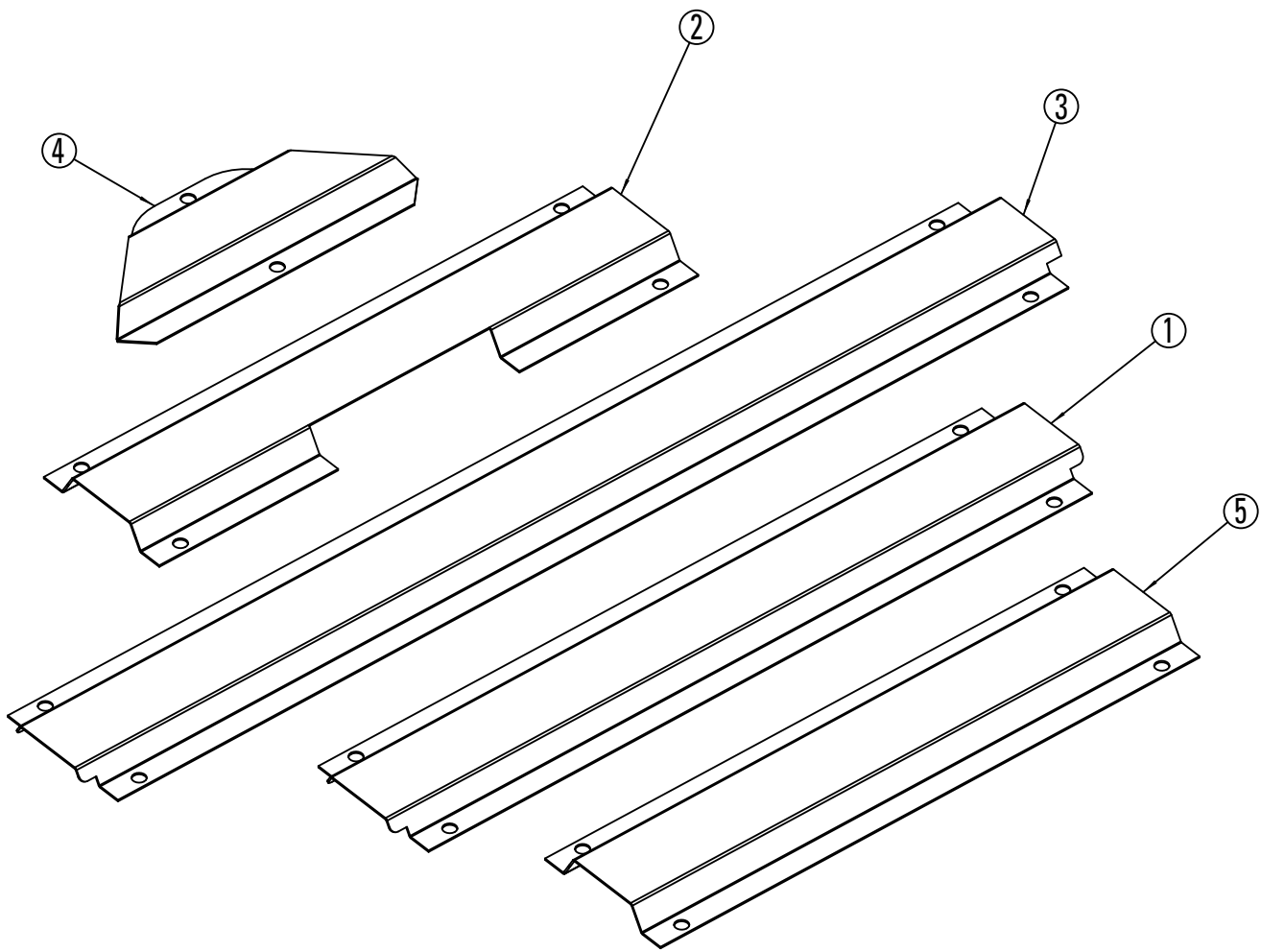

ARTÍCULO	CANT.	PIEZA NO.	DESCRIPCIÓN
1	2	XX130091Y	CUBIERTA DE LA MANGUERA
2	2	XX130092Y	CUBIERTA DE LA MANGUERA
3	2	XX130111Y	CUBIERTA DE LA MANGUERA
4	1	XX130141Y	CUBIERTA DE LA MANGUERA 45°
5	2	XX130156Y	CUBIERTA DE LA MANGUERA

Notes

Notas:

Notas:

Vehicle Service GroupSM
2700 Lanier Drive
Madison, IN 47250, USA
1-800-640-5438
www.vsgdover.com



© **Vehicle Service GroupSM**
Todos os direitos reservados. Salvo disposição
em contrário indicado, **Vehicle Service GroupSM**,
e todas as outras marcas registradas são de
propriedade da Dover Corporation e suas afiliadas.

Répartition des pièces

Section Double de la Table Élévatrice

(000 Séries)

Capacité 7,700 lbs (3,500 kg)
(Maximum 3,850 lbs (1,750 kg) par plaquette)

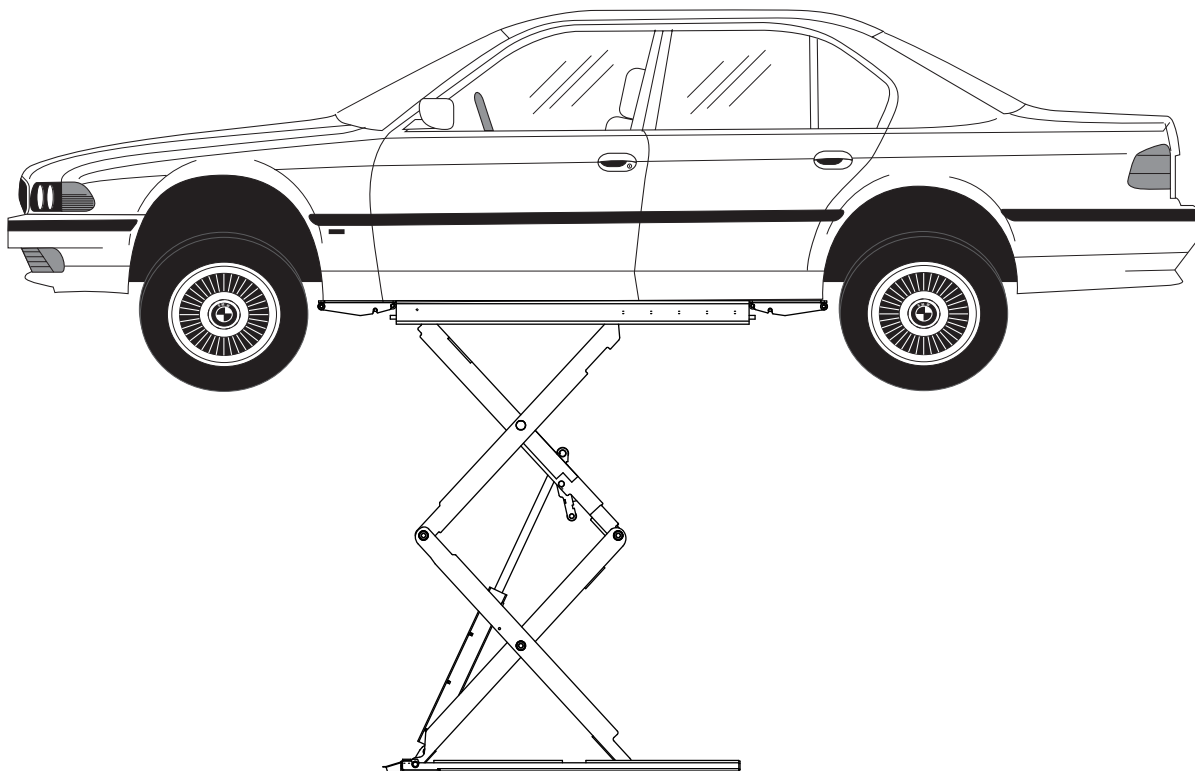

DOSSIER PROPRIÉTAIRE

Information complète
à droite et garder dans
un endroit sûr.

Date Installé _____

Installé dans le Segment # _____

Unité de puissance Série # _____

Unité de puissance Modèle # _____

Table élévatrice Série # _____

Table élévatrice Modèle # _____

NOTE : Pour des pièces de remplacement - Voir votre distributeur de pièces Rotary le plus proche.

LP20632

ITEM	NO. PIÈCE	DESCRIPTION
1	B21-6X10	GOUJON FILETÉ À 6 PANS CREUX À TÊTE PLATE M6X10
2	B22-6X10	GOUJON FILETÉ À 6 PANS CREUX À TÊTE POINTUE M6X10
3	B26-5X10	GOUJON À TÊTE PLATE FRAISÉE MS M5X10
4	FJ2427	BLOC DE CAOUTCHOUC
5	30400-1025	CALE
6	ML50-1605	LIBÉRATION DU CRAN DE SÛRETÉ À CYLINDRE À AIR
7	XX110001	ASSEMBLAGE KICKER
8	XX110003	RAMPE D'ASSEMBLAGE
9	XX120001	SOUDURE DE PLATEFORME
10	XX120002	SOUDURE DE BASE
11	XX120003	PATTE DE SOUDAGE EN CISEAU
12	XX120004	PATTE DE SOUDAGE EN CISEAU
13	XX120005	PATTE DE SOUDAGE EN CISEAU
14	XX120006	PATTE DE SOUDAGE EN CISEAU
16	XX120023	SOUDURE DE SERRURES DE LA TABLE ÉLÉVATRICE
17	XX120024	SOUDURE DE LA BARRE DU CROCHET DE VERROUILLAGE
18	XX130080	GOUPILLE, LONGUE
19	XX130081	GOUPILLE, LONGUE
20	XX130082	GOUPILLE DU CYLINDRE DU BAS
21	XX130086	GOUPILLE DU CYLINDRE DU HAUT
22	XX140005	CYLINDRE
23	XX140007	BLOC COULISSANT (INFÉRIEUR)
24	XX140008	BLOC COULISSANT SUPÉRIEUR
25	XX140014Y	SURFACE, 25 DIAM. X 25 LONG
26	XX140015Y	SURFACE, 25 DIAM. X 35 LONG
27	XX140019Y	SURFACE, 25 DIAM. X 50 LONG
28	XX140021	GOUPILLE DU CENTRE SUPÉRIEUR
29	XX140022	GOUPILLE DU CENTRE INFÉRIEUR
30	XX140023	GOUPILLE, LONGUE
31	XX140024	GOUPILLE, COURTE
32	XX140025	GOUPILLE DU CENTRE KICKER
33	XG130007	M20x1.0 S EMBOÎTEMENT ROND DU CONTRE-ÉCROU
34	XX140029	RONDELLE, PLASTIQUE MINCE
35	XX140064	FUSIBLE DE VITESSE
36	FJ2428	BLOC DE CAOUTCHOUC
37	XX140047	PLATEFORME PARE-CHOC
38	XX140048	PLATEFORME RAIL
39	XX140053Y	SURFACE, 20 DIAM. X 20 LONG
40	XX140054	RONDELLE, PLASTIQUE MINCE
41	XX140055	BLOC COULISSANT
42	XX140056	GOUPILLE
43	XX130214	GOUPILLE
44	B60-20	RESSORT D'ARRÊT
45	B30-10	ÉCROU
46	B201-10X65	BOULON À TÊTE HEXAGONALE M10 X 65
47	B63-25	RESSORT D'ARRÊT
48	XX140062	SURFACE, 25 DIAM. X 30 LONG
49	K35-7010	Ø19 RONDELLE
50	XX130210	COUSSIN DE SOUDAGE
51	SB700071Y	BLOC DE CAOUTCHOUC
52	B41-24	Ø24 RONDELLE
53	B35-5	M5 ÉCROU
54	NP945	PLAQUE SIGNALÉTIQUE
55	FJ1009	ANCRE
56	XX130225	PLAQUE EN ACIER INOXYDABLE
57	B25-6X12	VIS M6 X 12

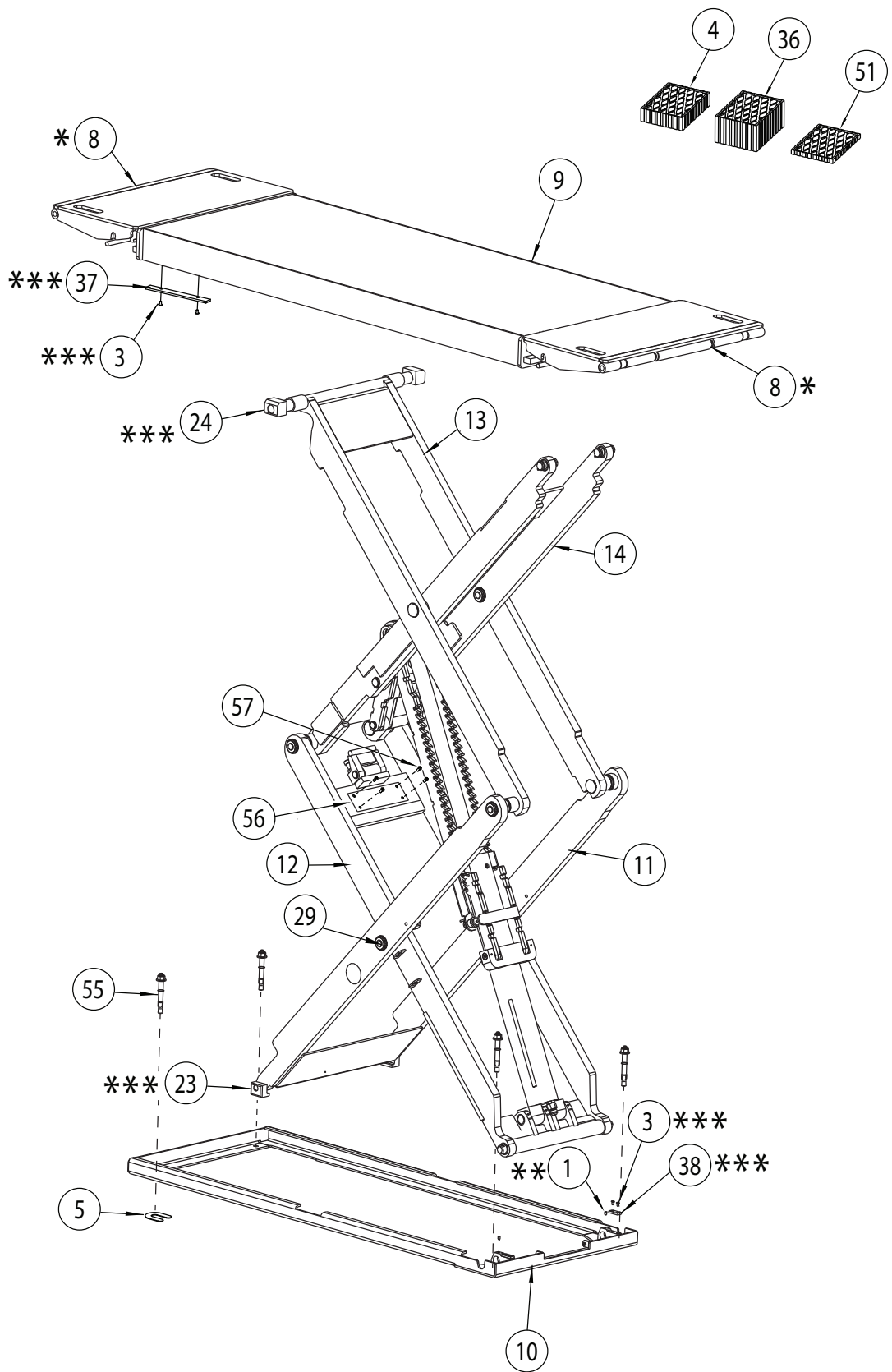

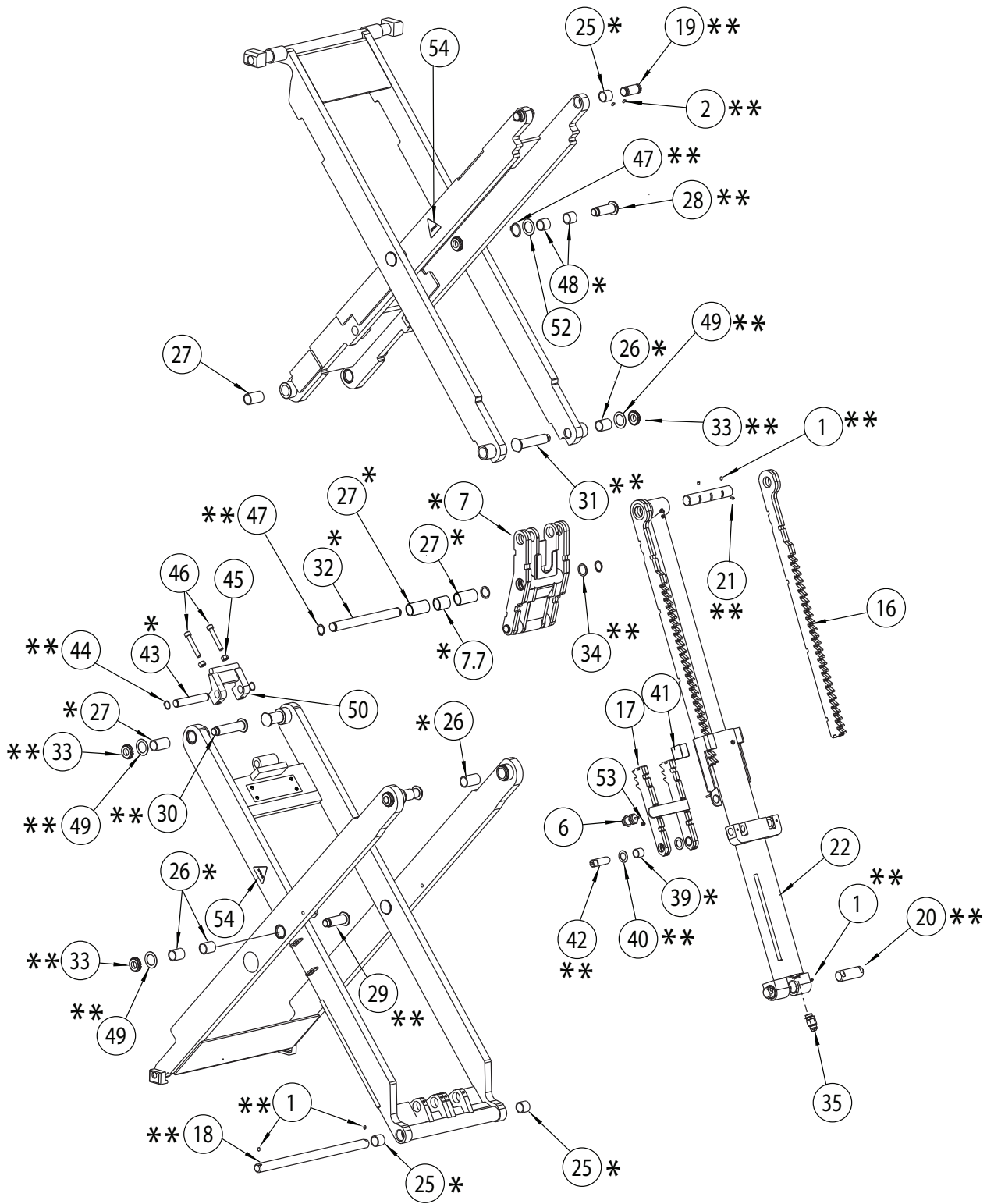

* NOTE : XX100011 ENSEMBLE DE REMPLACEMENT DU ROULEMENT INCLUANT UN ROULEMENT ANNOTÉ CI-AVANT POUR **UNE** PLATEFORME. POUR TOUTE LA TABLE ÉLEVATRICE, **DEUX** ENSEMBLES DE ROULEMENT DOIVENT ÊTRE COMMANDÉS.

** NOTE : XX100007 REMPLACEMENT D'UN ENSEMBLE DE GOUPILLES INCLUANT DES GOUPILLES ANNOTÉES CI-AVANT POUR **UNE** PLATEFORME. POUR TOUTE LA TABLE ÉLEVATRICE, **DEUX** ENSEMBLES DE ROULEMENT DOIVENT ÊTRE COMMANDÉS.

*** NOTE : XX100017 REMPLACEMENT D'UN ENSEMBLE DE COULISSEAUX INCLUANT DES COULISSEAUX ANNOTÉS CI-AVANT POUR LES **DEUX** PLATEFORMES (TABLE ÉLEVATRICE ENTIÈRE).

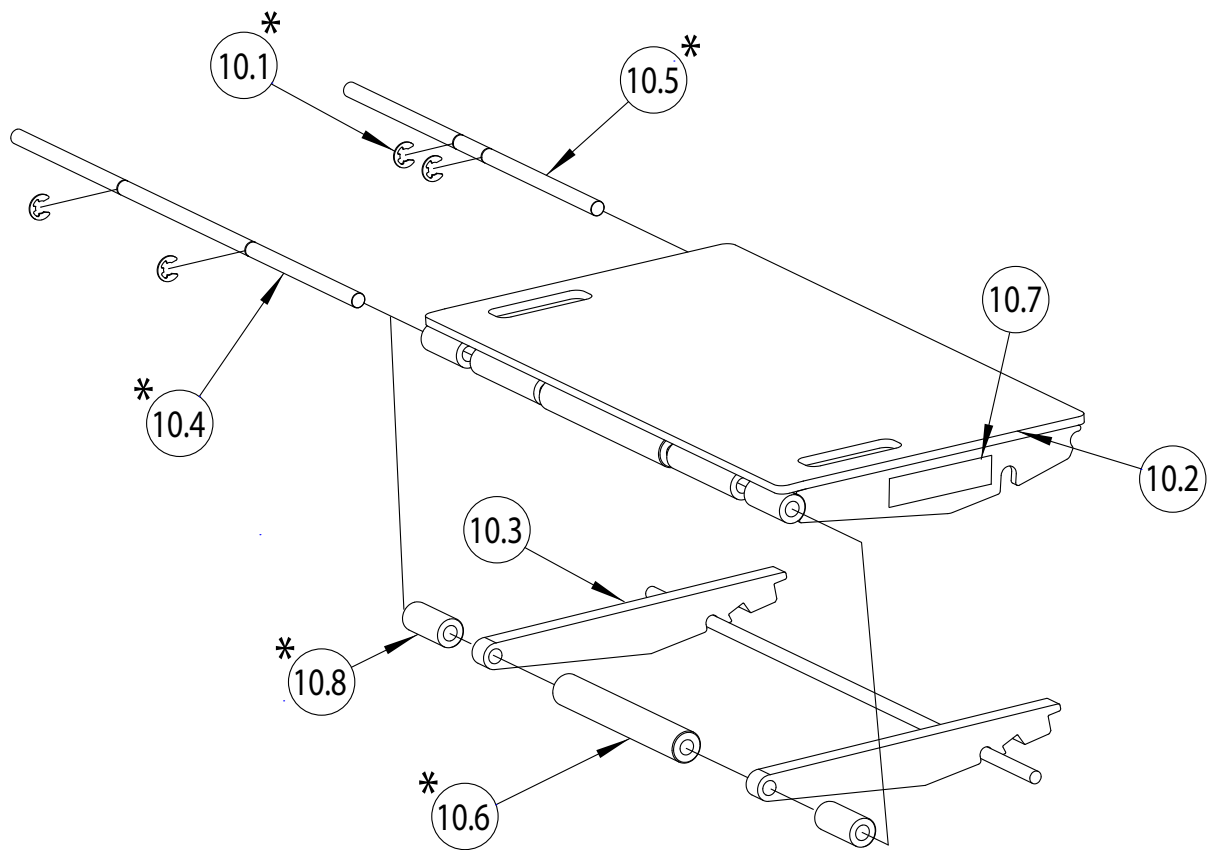

ASSEMBLAGE DE LA RAMPE

ITEM	NO. PIÈCE	DESCRIPTION
10.1	B61-12	E-AGRAFE 14MM
10.2	XX120007	SOUDEGE DE LA RAMPE
10.3	XX120008	SUPPORT DE SOUDAGE DE LA RAMPE
10.4	XX130063	RAMPE DE L'ARBRE DU ROULEAU
10.5	XX130064	RAMPE DE L'ARBRE DU ROULEAU
10.6	XX140009	RAMPE DU ROULEAU
10.7	NP1207	PLAQUE SIGNALÉTIQUE
10.8	XX130236	PETIT ROULEAU

* NOTE: XX100010 REMPLACEMENT DE L'ENSEMBLE DE LA RAMPE DU ROULEAU INCLUANT LE ROULEAU ANNOTÉ ET LES PIÈCES DE L'ARBRE DU ROULEAU POUR QUATRE RAMPES.

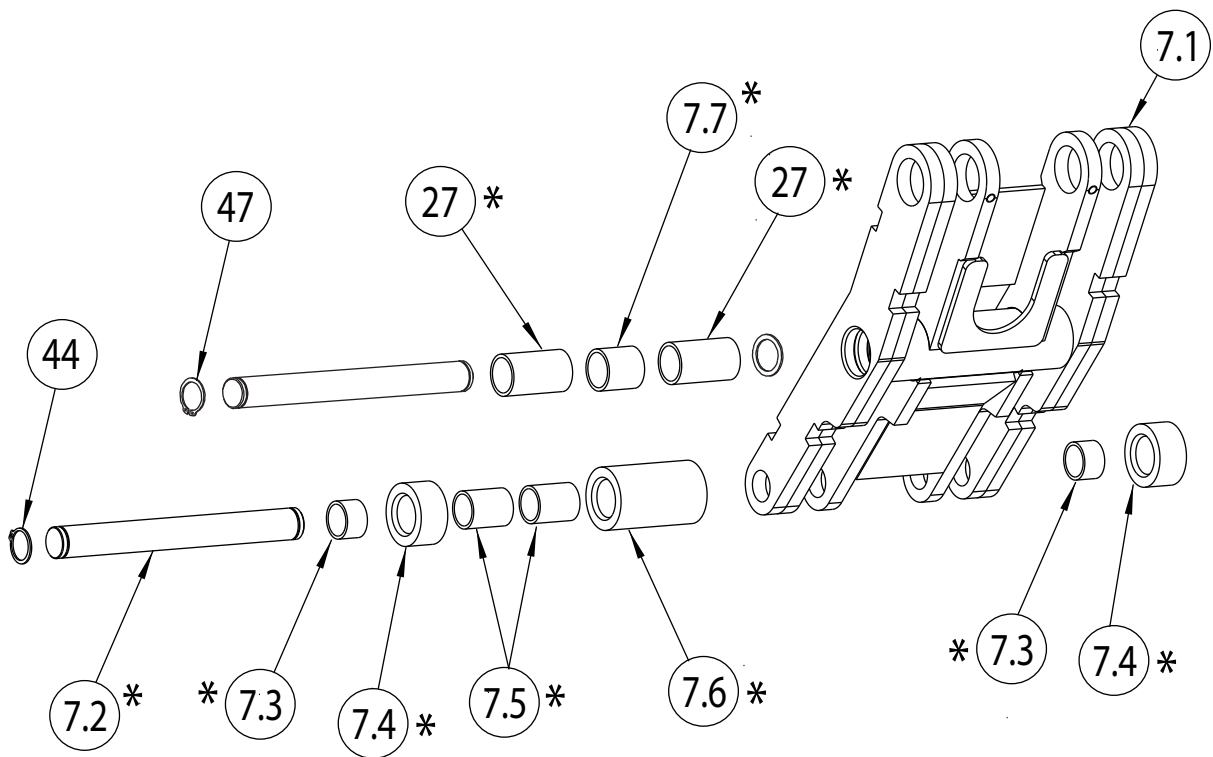

ASSEMBLAGE DU KICKER

ITEM	NO. PIÈCE	DESCRIPTION
7.1	XX120009	SOUDURE DU KICKER
7.2	XX130036	AXE DE GALET
7.3	XX140060	SURFACE, 20 DIAM. X 15 LONG
7.4	XX140020	ROULEAU
7.5	XX140059	SURFACE, 25 DIAM. X 30 LONG
7.6	XX140004	ROULEAU
7.7	XX140068Y	SURFACE, 25 DIAM. X 30 LONG

* NOTE : XX100008 REMPLACEMENT DE L'ENSEMBLE À ROULEAU INCLUANT LES PIÈCES POUR L'ARBRE À ROULEAU ET LE ROULEMENT ANNOTÉES POUR DEUX PLATEFORMES.

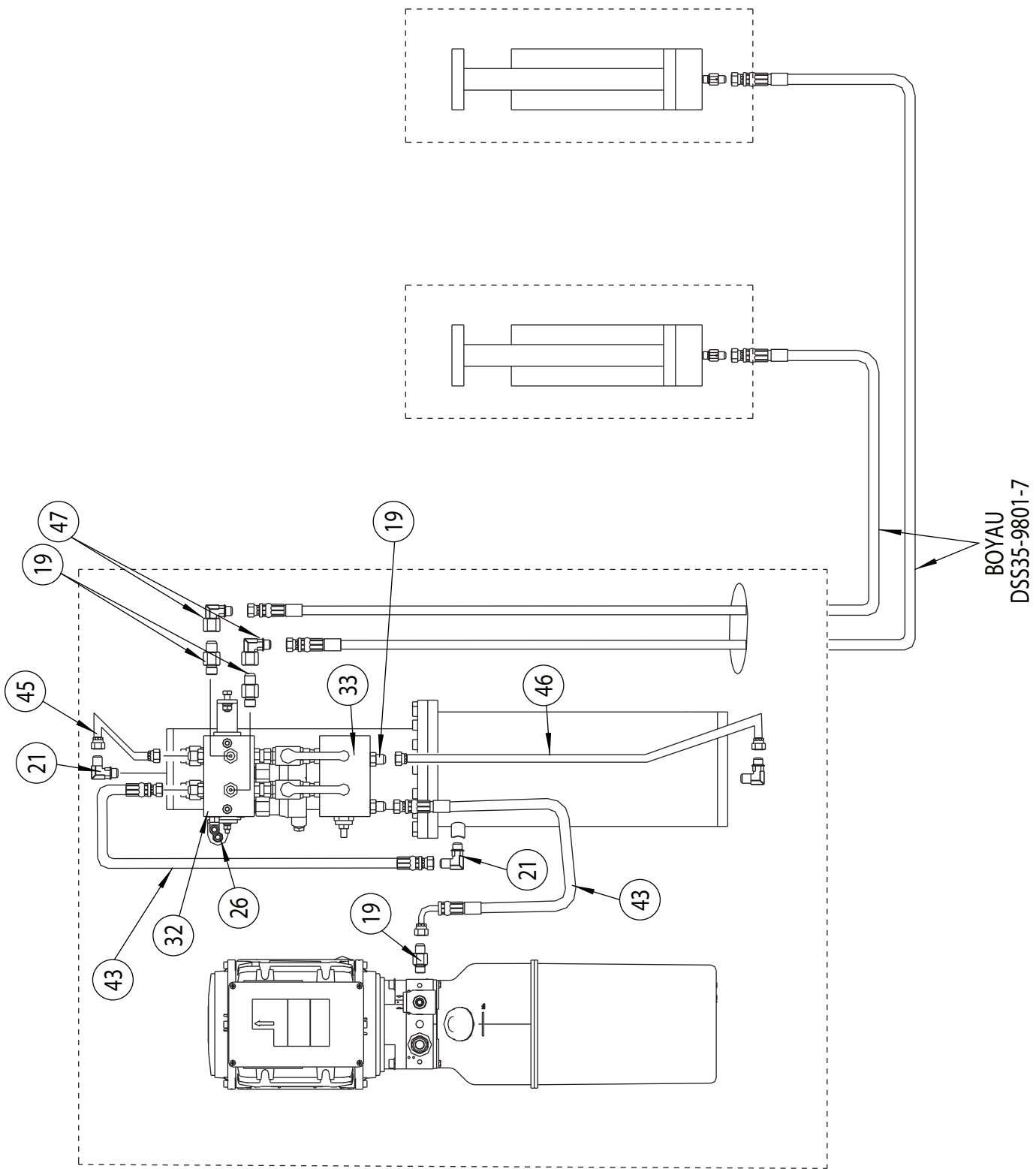

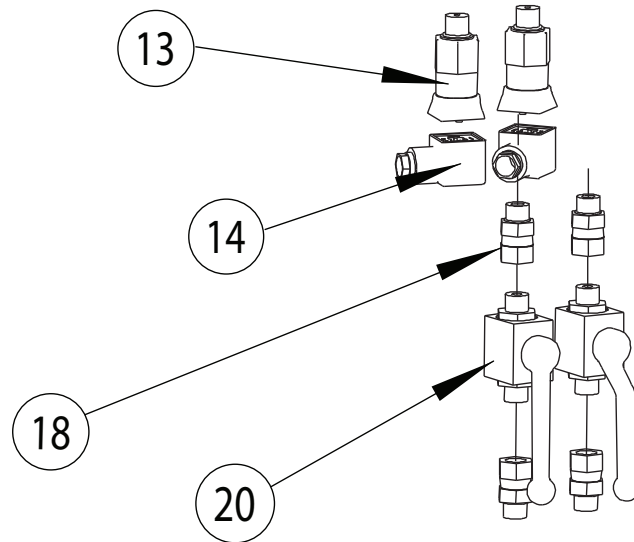

ITEM	QTÉ	NO. PIÈCE	DESCRIPTION
13	2	BAF-SR-65-C-H-9-UL	INTERRUPTEUR DE PRESSION
14	2	C18311N21	CONNECTEUR DIN
18	4	DSS35-9802-1	RACCORD
20	2	3288813	CLAPET À BILLE

ITEM	NO. PIÈCE	DESCRIPTION
1	B42-8	8MM GROSSE RONDELLE
2	B10-6X12	BOULON À TÊTE HEXAGONALE À BRIDE M6X12
3	AB302	SERRURE
4	B10-8X25	BOULON À TÊTE HEXAGONALE M8X25
5	B10-6X25	BOULON À TÊTE HEXAGONALE M6X25
6	B20-8X70	DOUILLE HEXAGONALE À VIS À TÊTE BOUCHON M8X70
7	B30-6	ÉCROU HEXAGONALE M6
8	B30-8	ÉCROU HEXAGONALE M8
9	B40-6	RONDELLE DE BLOCAGE 6
10	B40-8	RONDELLE DE BLOCAGE 8
11	B41-6	RONDELLE PLATE 6
12	B41-8	RONDELLE PLATE
13	BAF-5R-6S-C-H-9-UL	INTERRUPTEUR DE PRESSION
14	C18311N21	CONNECTEUR DIN
15	XX130195	COUVERCLE ÉLECTRIQUE
16	B23-4X6	VIS 4X6, PHMS
17	PG135	SERRE-CÂBLE
18	DSS35-9802-1	RACCORD
19	FJ7352-3	ADAPTATEUR
20	3288813	CLAPET À BILLE
21	SW-002	RACCORD COUDÉ
22	P3668	1Ø 60Hz 220V UNITÉ DE PUISSANCE
	P3671	1Ø 50Hz 220V UNITÉ DE PUISSANCE
	P3660	3Ø 50/60Hz 460V UNITÉ DE PUISSANCE
23	DQ-QJ-00053	INTERRUPTEUR D'ALIMENTATION (DR-100-24)
24	DQ-QJ-00056	PONT REDRESSEUR (KBPC2510)
25	PV-2005	L'UNITÉ DE PUISSANCE RELIE LA TIGE AVEC LE PARE-CHOC
26	EPC8-G02	RACCORD D'AIR -Y
27	XX110014	CABINET, VERSION AMÉRICAINNE
28	XX130178	BAGUE DU CYLINDRE DU CABINET
29	XX130179	AGRAFE DE SOUTIEN DU CABINET
30	XX130190	AGRAFE DE SOUTIEN DU CABINET
31	XX140058	CYLINDRE MAÎTRE
32	FKZJ-201C	COLLECTEUR
33	FKZJ-201B	COLLECTEUR
34	XX140065	LIBÉRATION DU CRAN DE SÛRETÉ À VALVE CYLINDRIQUE
35	DQ-QJ-00038	VOYANT D'ALIMENTATION
36	DQ-QJ-00002	BOUTON-POUSSOIR MONTER (XX110018)
37	DQ-QJ-00001	BOUTON-POUSSOIR DESCENDRE (XX110018)
38	DQ-QJ-00034	SECTIONNEUR
39	DQ-QJ-00050	BLOC DE JONCTION (XX110017, XX110020)
	DQ-QJ-00055	BLOC DE JONCTION (XX110018)
40	AG-25W	CONTRE-ÉCROU
41	XX100026	TRANSFORMEUR (XX110018)
	DQ-QJ-00035	TRANSFORMEUR (XX110018)
42	DQ-QJ-00005	CONTACTEUR (XX110018)
43	DBS35-9801-1	BOYAU HYDRAULIQUE
44	XX140037	FUSIBLE DE VITESSE
45	DSS35-9801	TUYAU D'ACIER HYDRAULIQUE
46	DSS35-9801	TUYAU D'ACIER HYDRAULIQUE
47	M130028Y	RACCORD COUDÉ
48	B14-3/8X70	ANCRAGE DE CABINET
49	NA	NA
50	DQ-QJ-00052	RELAIS DE PUISSANCE
51	DR-100-24	INTERRUPTEUR D'ALIMENTATION
52	KBPC2510	PONT REDRESSEUR
53	S130080	FILTRE-RÉGULATEUR-LUBRIFICATEUR
54	FCS191-6	CONNECTEUR MÂLE
55	EPL6-N02	COUDE MÂLE
56	FCS185-96	COUDE MÂLE
57	FC147-1	CLOISON FEMELLE
58	DQ-QJ-00046	BARRE DE MISE À LA TERRE

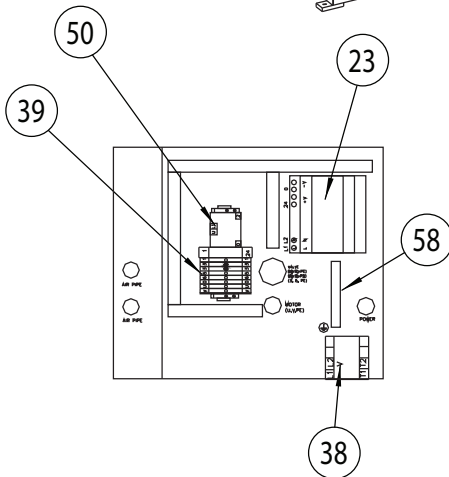
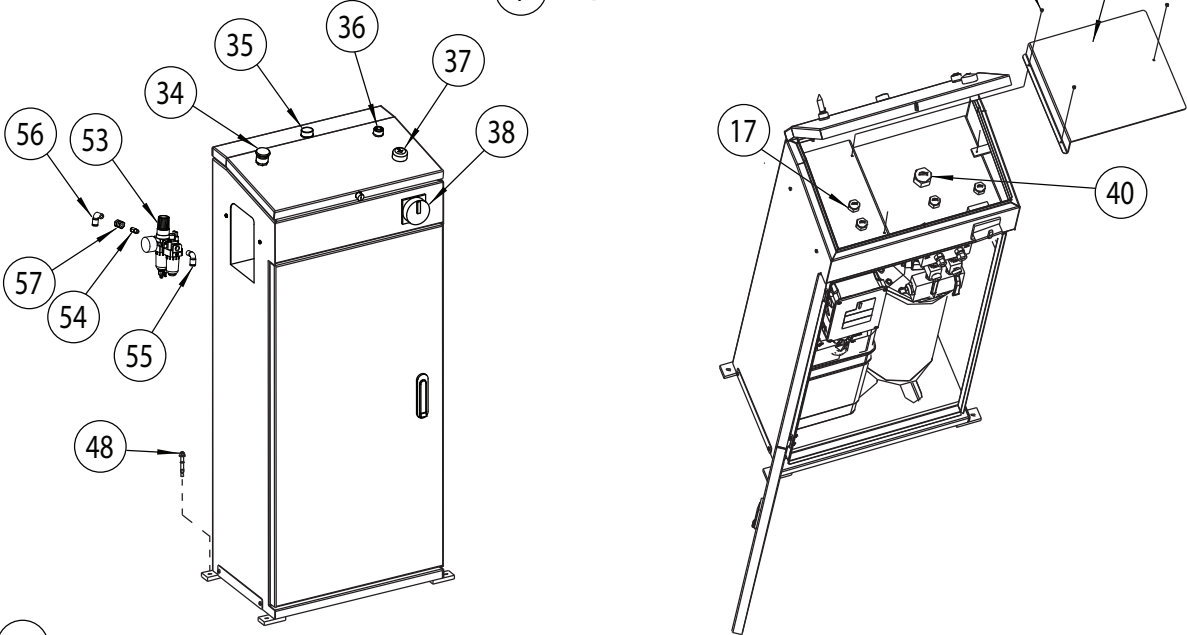
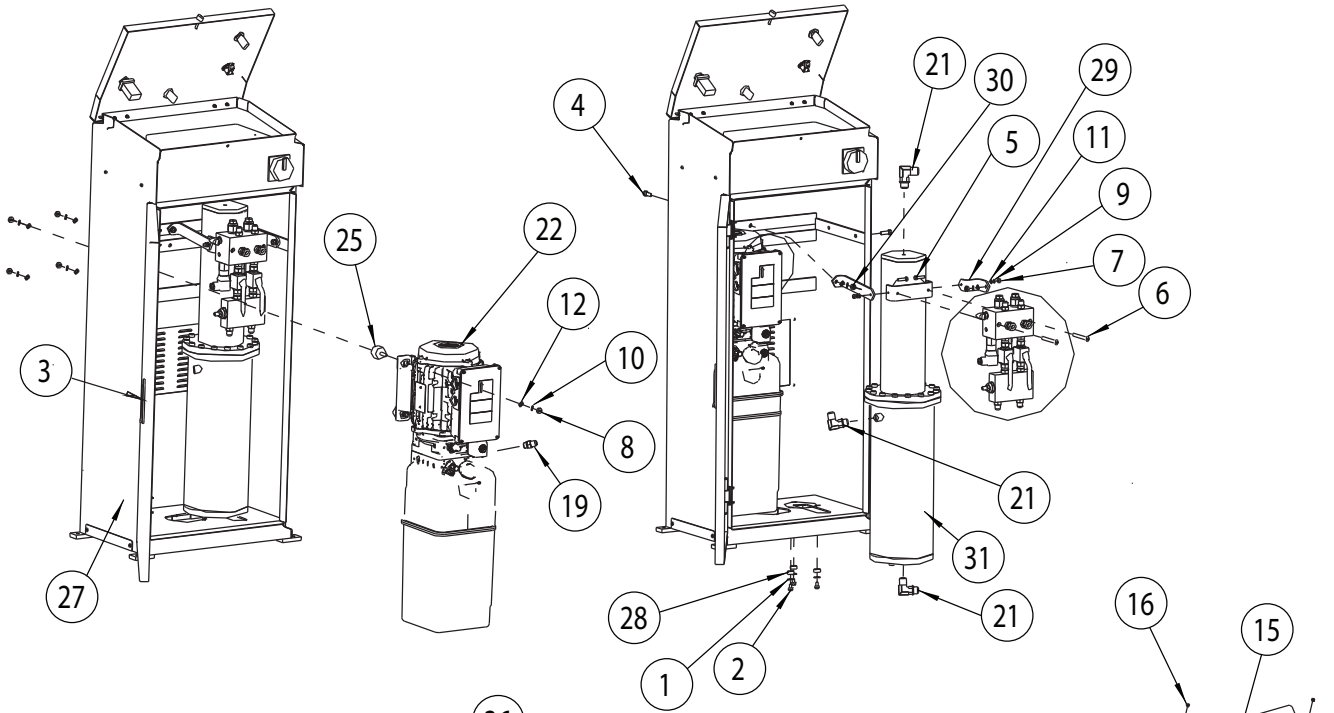

XX110017, XX110020

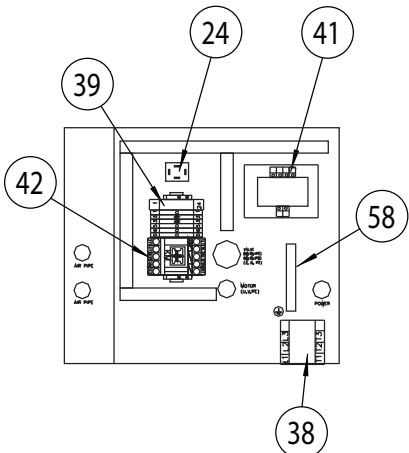

XX110018 AVEC XX100026

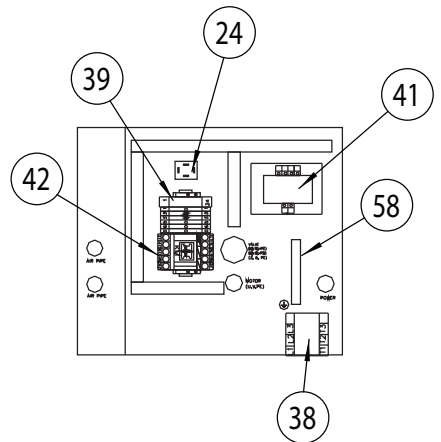

XX110018

XXI00020 ENSEMBLE DE MONTAGE
DU FLUX DE PAUSE DE L'ALCÔVE

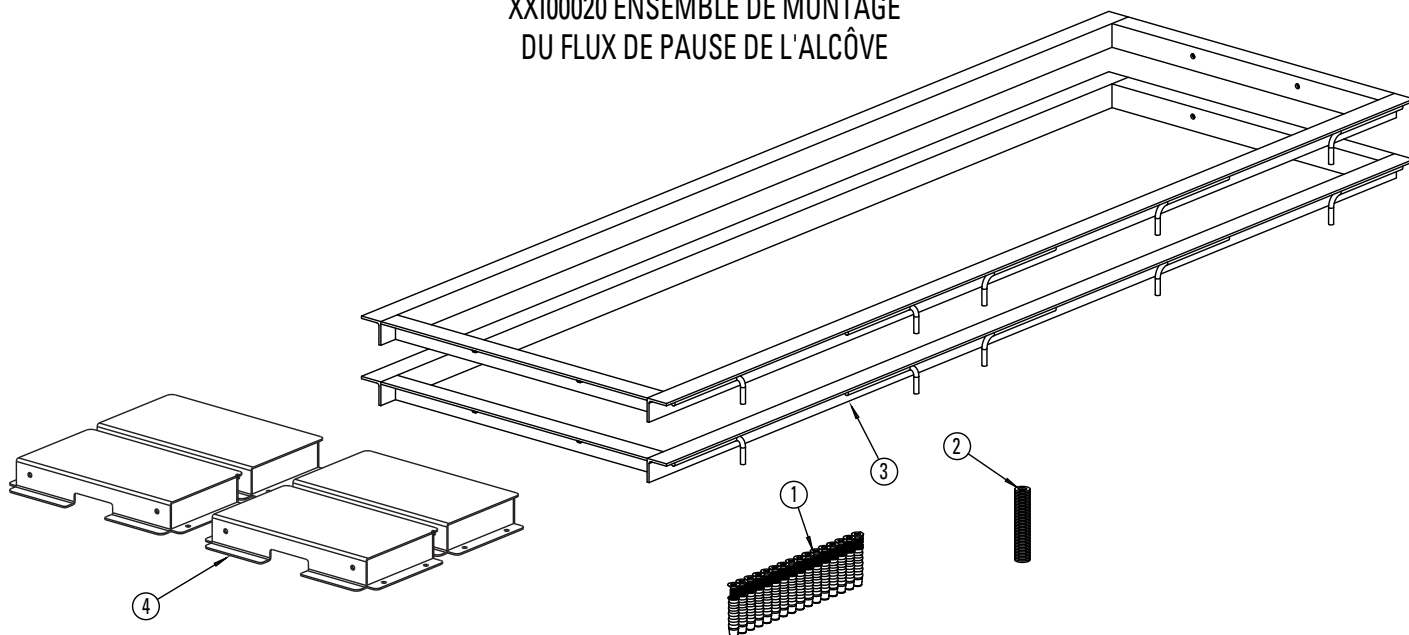

ITEM	QTÉ	NO. PIÈCE	DESCRIPTION
1	16	B14B-6X40	ANCRAGE EN NYLON
2	16	B41-8	RONDELLE PLATE Ø 8
3	2	XX120022	ALCÔVE DE SOUDAGE

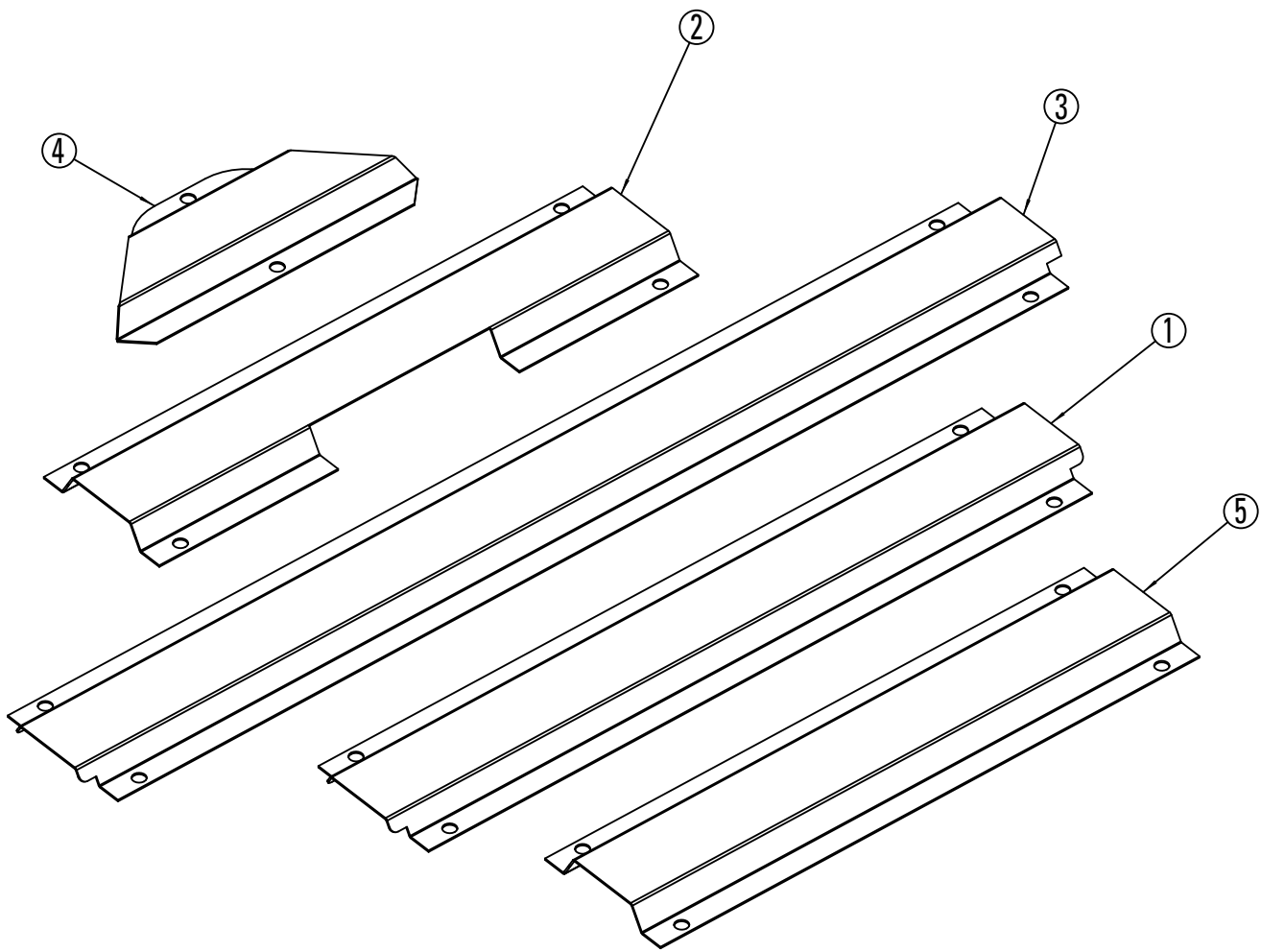

ITEM	QTÉ	NO. PIÈCE	DESCRIPTION
1	2	XX130091Y	COUVRE-BOYAU
2	2	XX130092Y	COUVRE-BOYAU
3	2	XX130111Y	COUVRE-BOYAU
4	1	XX130141Y	COUVRE-BOYAU 45°
5	2	XX130156Y	COUVRE-BOYAU

Remarques

Remarques

Remarques

Vehicle Service GroupSM
2700 Lanier Drive
Madison, IN 47250, États-Unis
1-800-640-5438
www.vsgdover.com



© **Vehicle Service GroupSM**
Tous droits réservés. À moins d'indication contraire,
Vehicle Service GroupSM, et toutes les autres
marques déposées sont la propriété de
Dover Corporation et ses filiales.

Descrição de peças

Elevador de tesoura de dupla seção

(Série 000)

Capacidade 7.700 lb (3.500 kg)
(Máximo de 3.850 lb - 1.750 kg - por calço)

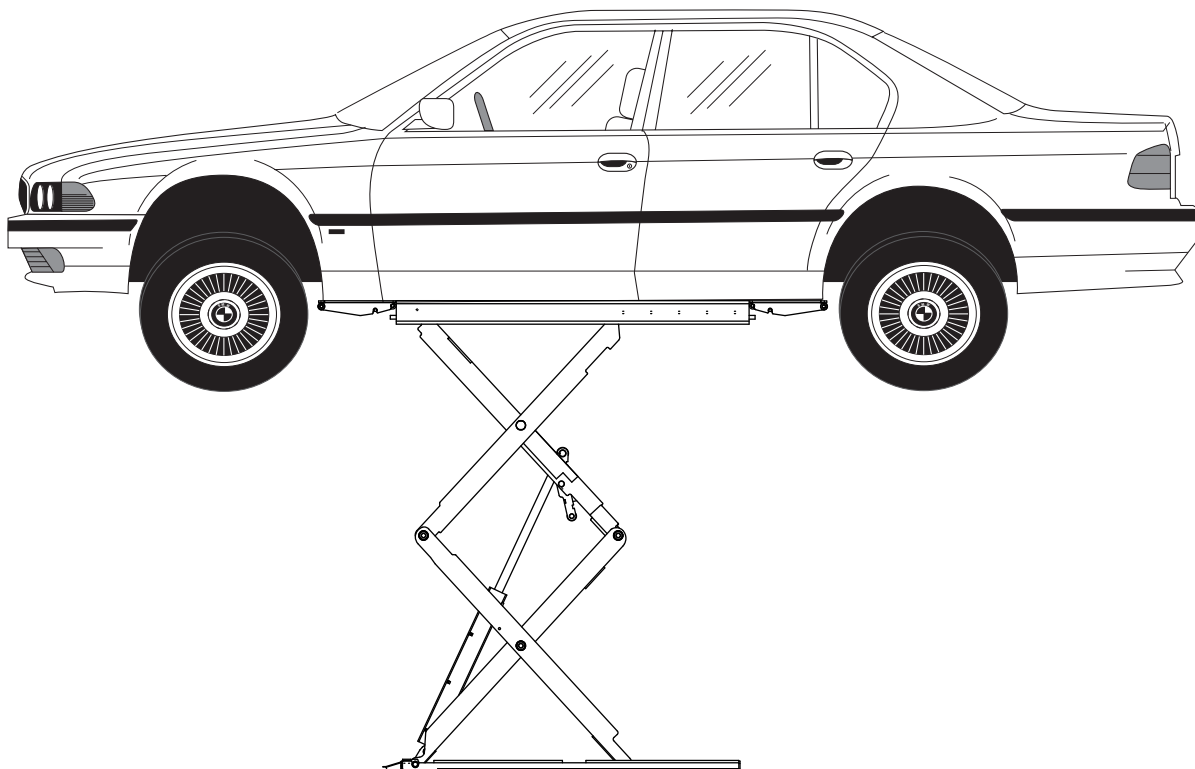

REGISTRO DO PROPRIETÁRIO

Preencha as informações corretamente e mantenha em um local seguro.

Data de instalação _____

Instalado na baia nº _____

Nº de série da unidade de potência _____

Nº do modelo da unidade de potência _____

Nº de série do elevador _____

Nº do modelo do elevador _____

OBSERVAÇÃO: Para peças de reposição - Consulte o seu distribuidor de peças Rotary mais próximo.

LP20632

ITEM	Nº DA PEÇA	DESCRIÇÃO
1	B21-6X10	PARAFUSO DO CONJUNTO DE SOQUETE SEXTAVADO COM CABEÇA PLANA M6X10
2	B22-6X10	PARAFUSO DO CONJUNTO DE SOQUETE SEXTAVADO COM CABEÇA PONTUDA M6X10
3	B26-5X10	SOQUETE DE CABEÇA PLANA EMBUTIDA MS M5X10
4	FJ2427	BLOCO DE BORRACHA
5	30400-1025	CALÇO
6	ML50-1605	TRAVA DE LIBERAÇÃO DO CILINDRO DE AR
7	XX110001	CONJUNTO DO TIRANTE
8	XX110003	CONJUNTO DA RAMPA
9	XX120001	SOLDAGEM DA PLATAFORMA
10	XX120002	SOLDAGEM DA BASE
11	XX120003	SOLDA DA PERNA DA TESOURA
12	XX120004	SOLDA DA PERNA DA TESOURA
13	XX120005	SOLDA DA PERNA DA TESOURA
14	XX120006	SOLDA DA PERNA DA TESOURA
16	XX120023	SOLDAGEM DAS TRAVAS DO ELEVADOR
17	XX120024	SOLDA DA BARRA DA TRAVA DE MANDÍBULA
18	XX130080	PINO, LONGO
19	XX130081	PINO, LONGO
20	XX130082	PINO DO CILINDRO INFERIOR
21	XX130086	PINO DO CILINDRO SUPERIOR
22	XX140005	CILINDRO
23	XX140007	BLOCO DESLIZANTE (INFERIOR)
24	XX140008	BLOCO DESLIZANTE (SUPERIOR)
25	XX140014Y	ROLAMENTO, 25 DIÂM. X 25 LONGO
26	XX140015Y	ROLAMENTO, 25 DIÂM. X 35 LONGO
27	XX140019Y	ROLAMENTO, 25 DIÂM. X 50 LONGO
28	XX140021	PINO CENTRAL SUPERIOR
29	XX140022	PINO CENTRAL INFERIOR
30	XX140023	PINO, LONGO
31	XX140024	PINO, CURTO
32	XX140025	PINO CENTRAL DO TIRANTE
33	XG130007	CONTRAPORCA ARREDONDADA COM FENDA M20x1.0
34	XX140029	ARRUELA, PLÁSTICA FINA
35	XX140064	FUSÍVEL DE VELOCIDADE
36	FJ2428	BLOCO DE BORRACHA
37	XX140047	AMORTECEDOR DA PLATAFORMA
38	XX140048	TRILHO DA PLATAFORMA
39	XX140053Y	ROLAMENTO, 20 DIÂM. X 20 LONGO
40	XX140054	ARRUELA, PLÁSTICA FINA
41	XX140055	BLOCO DESLIZANTE
42	XX140056	PINO
43	XX130214	PINO
44	B60-20	ANEL DE PRESSÃO
45	B30-10	PORCA
46	B201-10X65	PARAFUSO SEXTAVADO M10 X 65
47	B63-25	ANEL DE PRESSÃO
48	XX140062	ROLAMENTO, 25 DIÂM. X 30 LONGO
49	K35-7010	ARRUELA Ø19
50	XX130210	SOLDAGEM DO COXIM
51	SB700071Y	BLOCO DE BORRACHA
52	B41-24	ARRUELA Ø24
53	B35-5	PORCA M5
54	NP945	PLACA DE IDENTIFICAÇÃO
55	FJ1009	FIXAÇÃO
56	XX130225	PLACA DE AÇO INOXIDÁVEL
57	B25-6X12	PARAFUSO M6 X 12

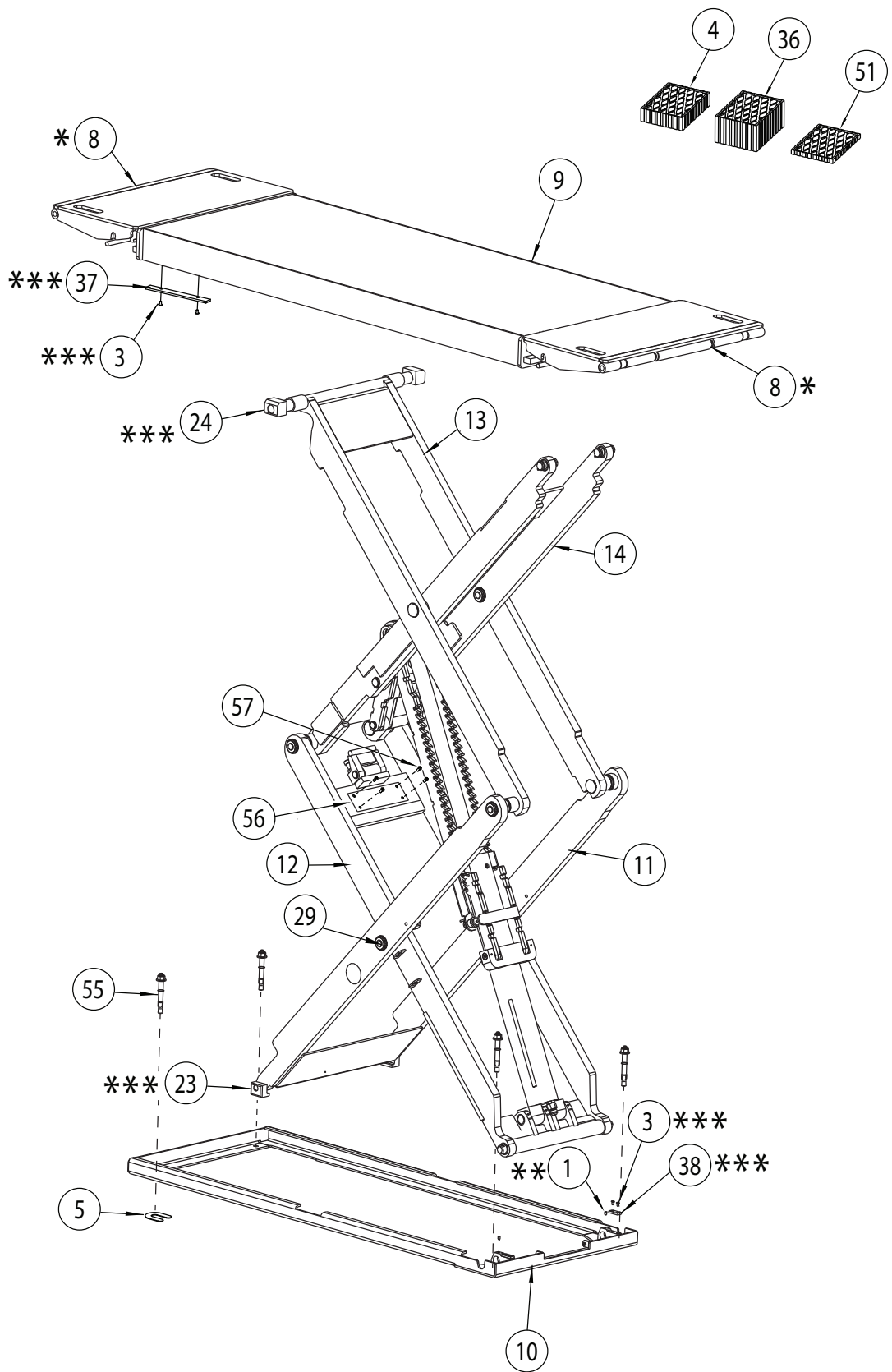

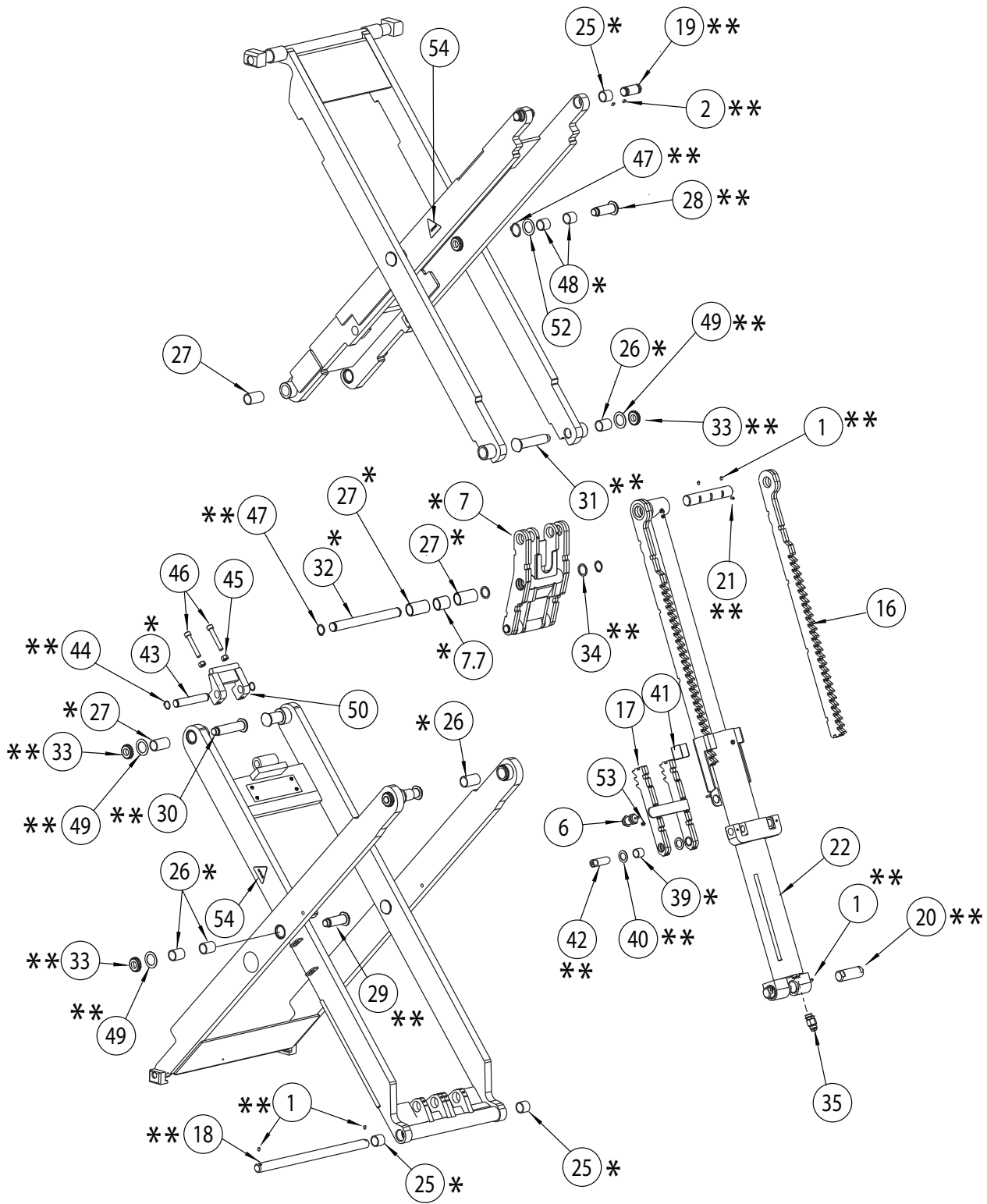

* OBSERVAÇÃO: O CONJUNTO DE SUBSTITUIÇÃO DO ROLAMENTO XX100011 INCLUI OS ROLAMENTOS DESCRITOS ACIMA PARA **UMA** PLATAFORMA. PARA O ELEVADOR COMPLETO **DOIS** CONJUNTOS DE ROLAMENTOS DEVEM SER SOLICITADOS.

** OBSERVAÇÃO: O CONJUNTO DE SUBSTITUIÇÃO DO PINO XX100007 INCLUI OS PINOS DESCRITOS ACIMA PARA **UMA** PLATAFORMA. PARA O ELEVADOR COMPLETO **DOIS** CONJUNTOS DE PINOS DEVEM SER SOLICITADOS.

*** OBSERVAÇÃO: O CONJUNTO DE SUBSTITUIÇÃO DO DESLIZADOR XX100017 INCLUI OS DESLIZADORES DESCRITOS ACIMA PARA **AMBAS** AS PLATAFORMAS (ELEVADOR COMPLETO).

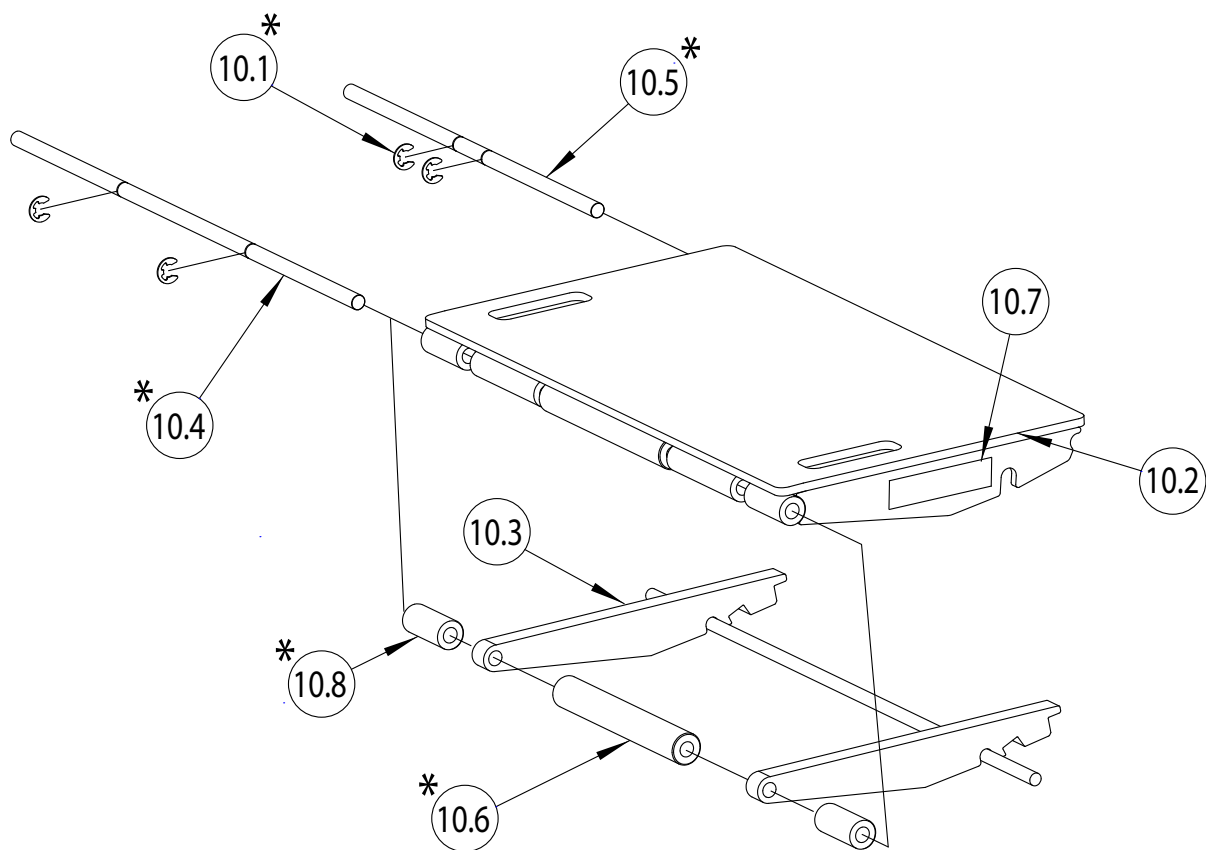

CONJUNTO DA RAMPA

ITEM	Nº DA PEÇA	DESCRIÇÃO
10.1	B61-12	E-CLIP 14 MM
10.2	XX120007	SOLDAGEM DA RAMPA
10.3	XX120008	SOLDAGEM DO SUPORTE DA RAMPA
10.4	XX130063	EIXO DO ROLO DA RAMPA
10.5	XX130064	EIXO DO ROLO DA RAMPA
10.6	XX140009	ROLO DA RAMPA
10.7	NP1207	PLACA DE IDENTIFICAÇÃO
10.8	XX130236	ROLO PEQUENO

* OBSERVAÇÃO: O CONJUNTO DE SUBSTITUIÇÃO DO ROLO DA RAMPA XX100010 INCLUI OS ROLOS E EIXO DO ROLO DESCRITOS ACIMA PARA QUATRO RAMPAS.

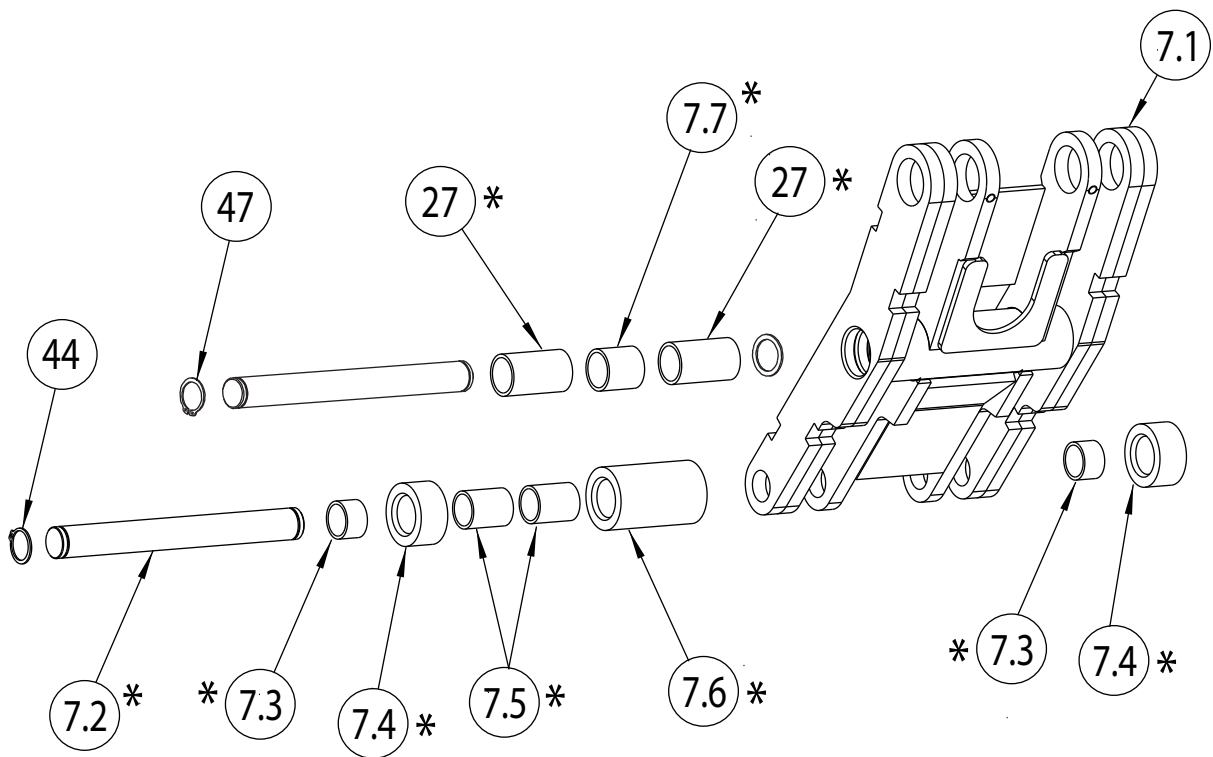

CONJUNTO DO TIRANTE

ITEM	Nº DA PEÇA	DESCRIÇÃO
7.1	XX120009	SOLDA DO TIRANTE
7.2	XX130036	PINO DO ROLO
7.3	XX140060	ROLAMENTO, 20 DIÂM. X 15 LONGO
7.4	XX140020	ROLO
7.5	XX140059	ROLAMENTO, 25 DIÂM. X 30 LONGO
7.6	XX140004	ROLO
7.7	XX140068Y	ROLAMENTO, 25 DIÂM. X 30 LONGO

* OBSERVAÇÃO: O CONJUNTO DE SUBSTITUIÇÃO DO ROLO DA RAMPA XX100008 INCLUI O EIXO DO ROLO E PEÇAS DE ROLAMENTO PARA DUAS PLATAFORMAS.

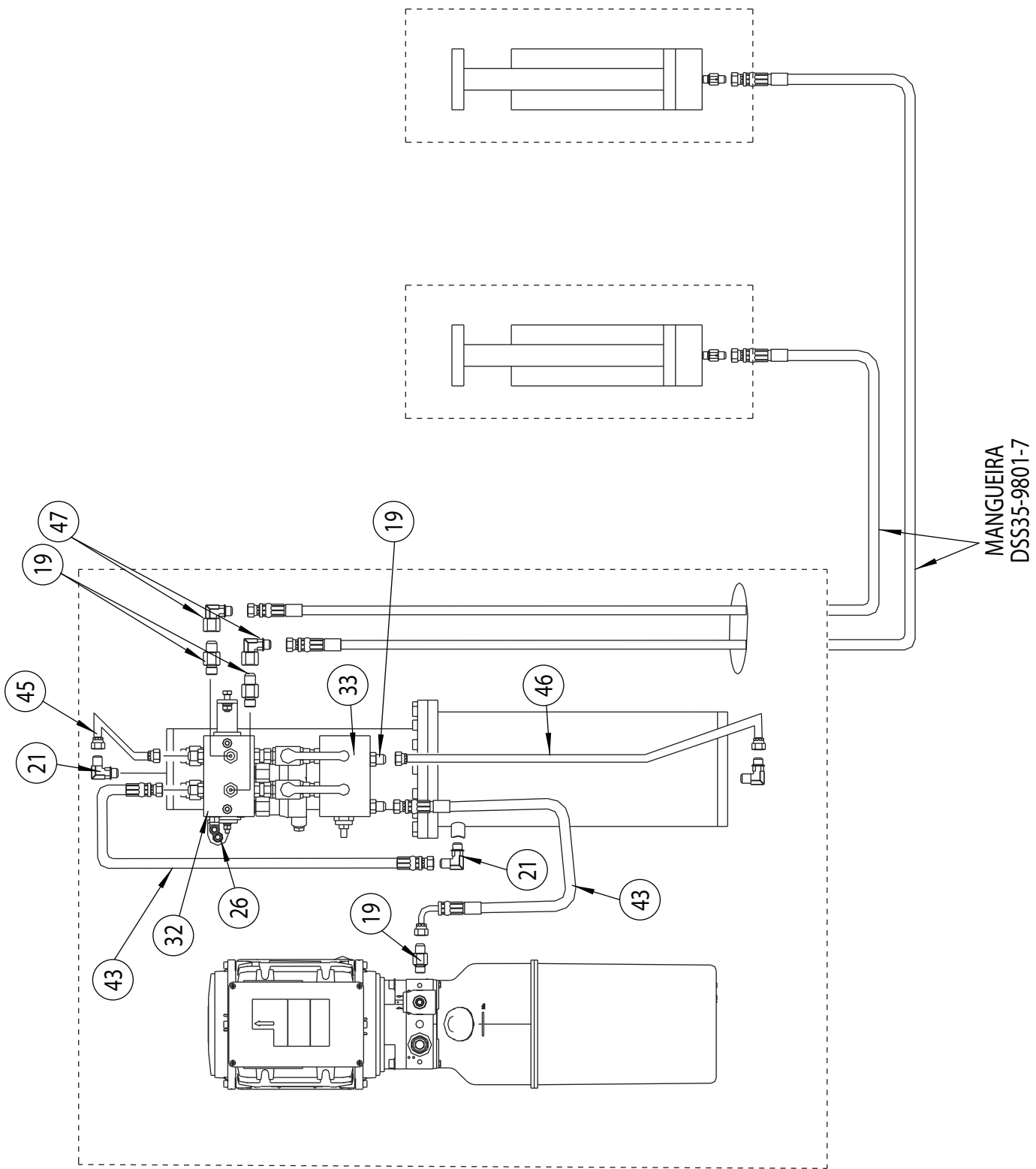

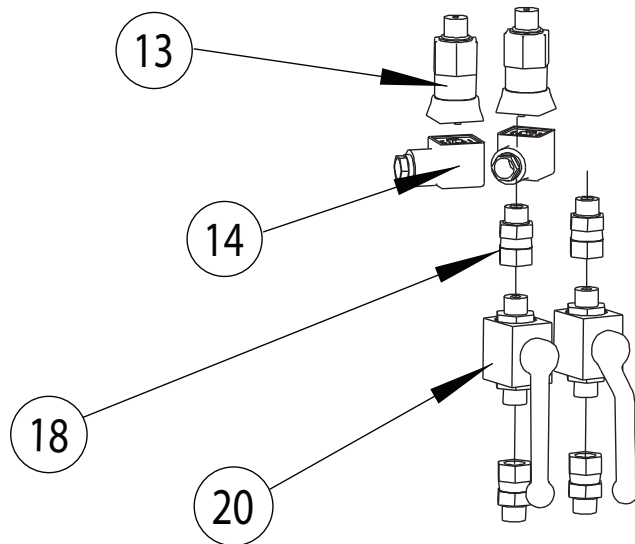

ITEM	QDE	Nº DA PEÇA	DESCRIÇÃO
13	2	BAF-SR-65-C-H-9-UL	CHAVE DE PRESSÃO
14	2	C18311N21	CONECTOR DIN
18	4	DSS35-9802-1	ENCAIXE
20	2	3288813	VÁLVULA DE ESFERA

ITEM	Nº DA PEÇA	DESCRIÇÃO
1	B42-8	ARRUELA GRANDE 8 MM
2	B10-6X12	PARAFUSO SEXTAVADO DE FLANGE M6X12
3	AB302	FERROLHO
4	B10-8X25	PARAFUSO DE CABEÇA SEXTAVADA M8X25
5	B10-6X25	PARAFUSO DE CABEÇA SEXTAVADA M6X25
6	B20-8X70	TAMPA DA CABEÇA DO PARAFUSO DO SOQUETE SEXTAVADO M8X70
7	B30-6	PORCA SEXTAVADA M6
8	B30-8	PORCA SEXTAVADA M8
9	B40-6	ARRUELA DE PRESSÃO 6
10	B40-8	ARRUELA DE PRESSÃO 8
11	B41-6	ARRUELA PLANA 6
12	B41-8	ARRUELA PLANA
13	BAF-5R-6S-C-H-9-UL	CHAVE DE PRESSÃO
14	C18311N21	CONECTOR DIN
15	XX130195	TAMPA ELÉTRICA
16	B23-4X6	PARAFUSO 4X6, PHMS
17	PG135	ADERÊNCIA DO CABO
18	DSS35-9802-1	ENCAIXE
19	FJ7352-3	ADAPTADOR
20	3288813	VÁLVULA DE ESFERA
21	SW-002	ENCAIXE DE COTOVELO
22	P3668	UNIDADE DE POTÊNCIA 1Ø 60 Hz 220 V
	P3671	UNIDADE DE POTÊNCIA 1Ø 50 Hz 220 V
	P3660	UNIDADE DE POTÊNCIA 3Ø 50/60 Hz 460 V
23	DQ-QJ-00053	CHAVE DA FONTE DE ALIMENTAÇÃO (DR-100-24)
24	DQ-QJ-00056	PONTE RETIFICADORA (KBPC2510)
25	PV-2005	HASTE DO CONEXÃO DA UNIDADE DE POTÊNCIA COM AMORTECEDOR
26	EPC8-G02	ENCAIXE DE AR -Y
27	XX110014	GABINETE, VERSÃO EUA
28	XX130178	MANCAL DO CILINDRO DO GABINETE
29	XX130179	SUORTE DO CILINDRO DO GABINETE
30	XX130190	SUORTE DO CILINDRO DO GABINETE
31	XX140058	CILINDRO MESTRE
32	FKZJ-201C	COLETOR
33	FKZJ-201B	COLETOR
34	XX140065	TRAVA DE LIBERAÇÃO DA VÁLVULA DE AR
35	DQ-QJ-00038	LUZ DE ENERGIA
36	DQ-QJ-00002	BOTÃO DE PRESSÃO DE SUBIDA (XX110018)
37	DQ-QJ-00001	BOTÃO DE PRESSÃO DE DESCIDA (XX110018)
38	DQ-QJ-00034	CHAVE DE DESCONEXÃO
39	DQ-QJ-00050	BLOCO TERMINAL (XX110017, XX110020)
	DQ-QJ-00055	BLOCO TERMINAL (XX110018)
40	AG-25W	PORCA DE PRESSÃO
41	XX100026	TRANSFORMADOR (XX110018)
	DQ-QJ-00035	TRANSFORMADOR (XX110018)
42	DQ-QJ-00005	CONTATOR (XX110018)
43	DBS35-9801-1	MANGUEIRA HIDRÁULICA
44	XX140037	FUSÍVEL DE VELOCIDADE
45	DSS35-9801	CANO DE AÇO HIDRÁULICO
46	DSS35-9801	CANO DE AÇO HIDRÁULICO
47	M130028Y	ENCAIXE DE COTOVELO
48	B14-3/8X70	FIXAÇÃO DO GABINETE
49	NA	NA
50	DQ-QJ-00052	RELÉ DE POTÊNCIA
51	DR-100-24	CHAVE DA FONTE DE ALIMENTAÇÃO
52	KBPC2510	PONTE RETIFICADORA
53	S130080	FILTRO-REGULADOR-LUBRICADOR
54	FC5191-6	CONECTOR MACHO
55	EPL6-N02	COTOVELO MACHO
56	FC5185-96	COTOVELO MACHO
57	FC147-1	ANTEPARO FÊMEA
58	DQ-QJ-00046	BARRA DE ATERRAMENTO

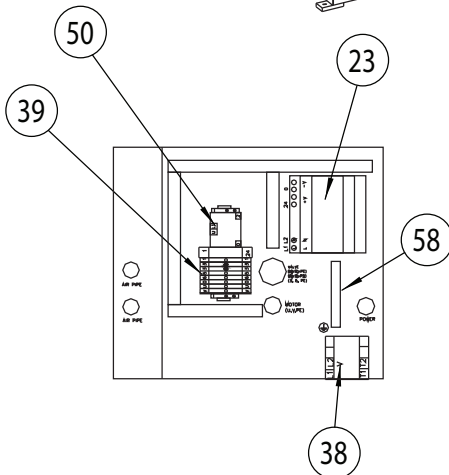
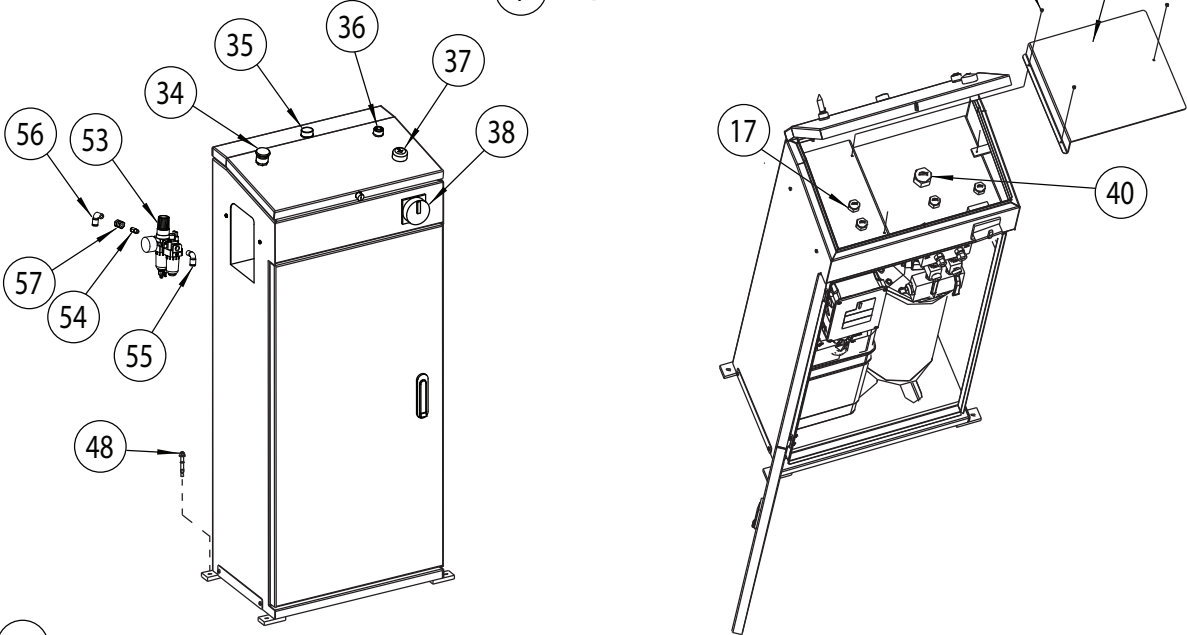
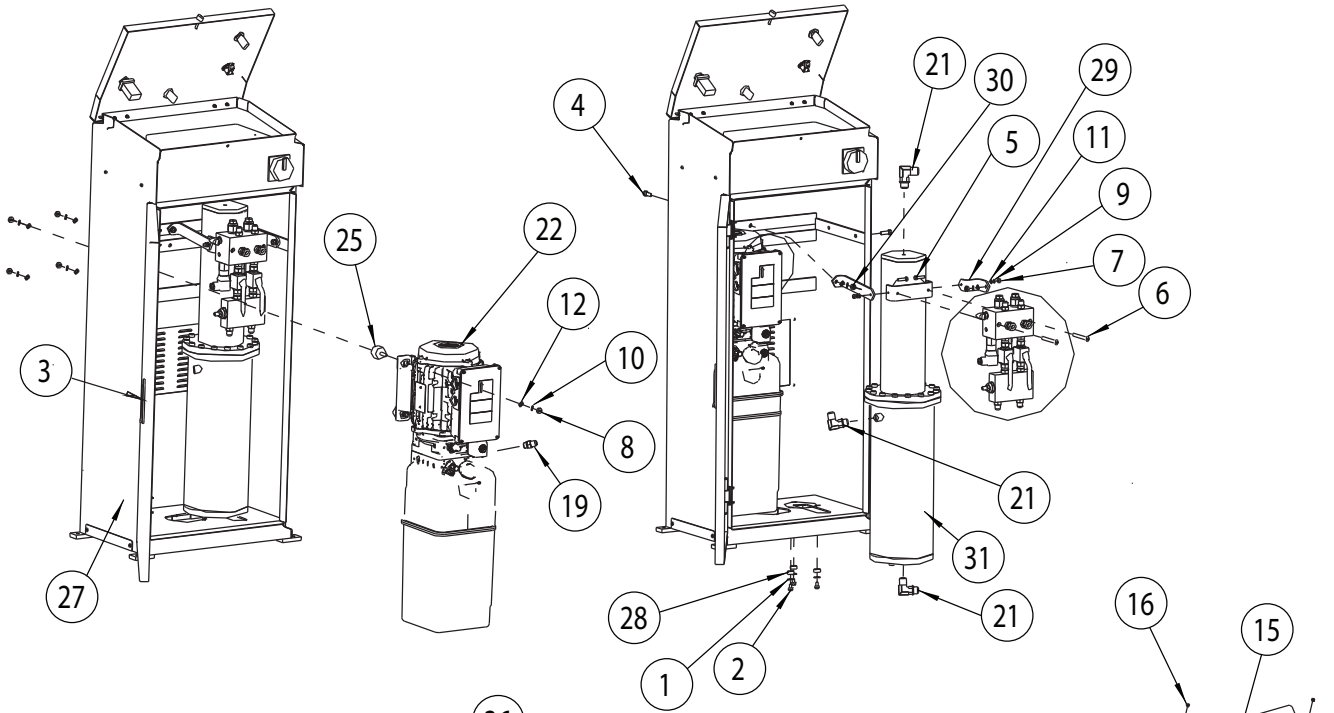

XX110017, XX110020

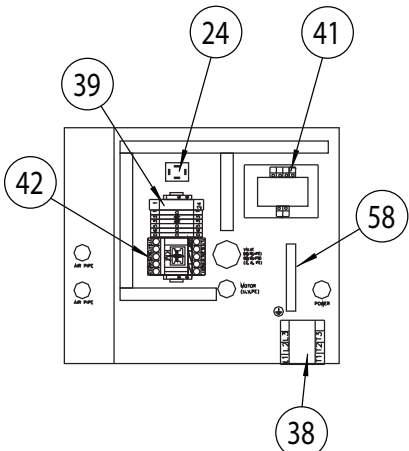

XX110018 COM XX10026

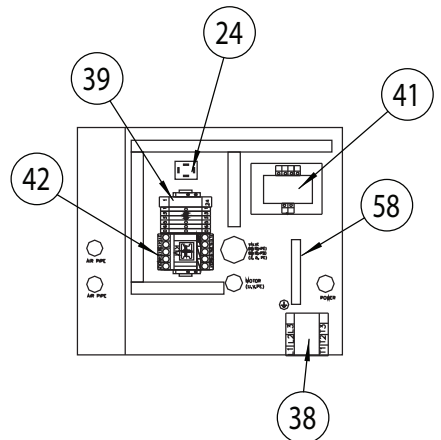

XX110018

XXI00020
 CONJUNTO MONTADO
 DO FLUXO DE RECESSO

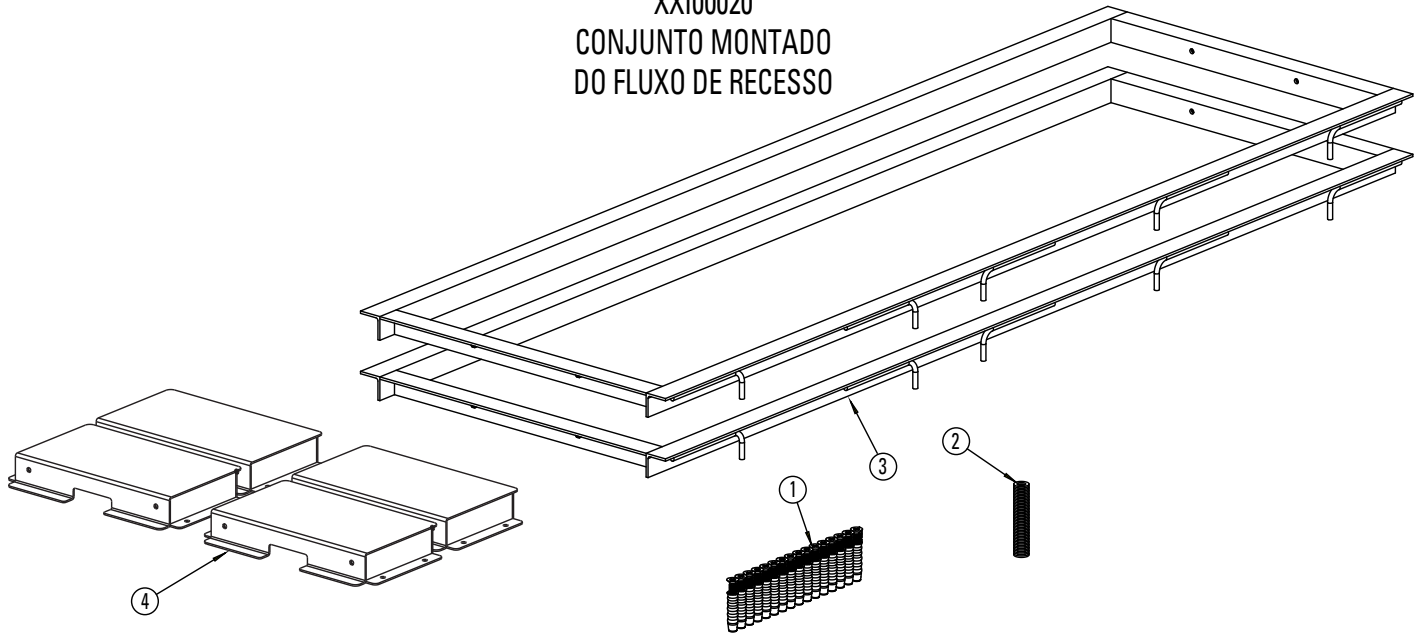

ITEM	QDE	Nº DA PEÇA	DESCRIÇÃO
1	16	B14B-6X40	FIXADOR DE NÁILON
2	16	B41-8	ARRUELA PLANA Ø8
3	2	XX120022	SOLDAGEM DO RECESSO

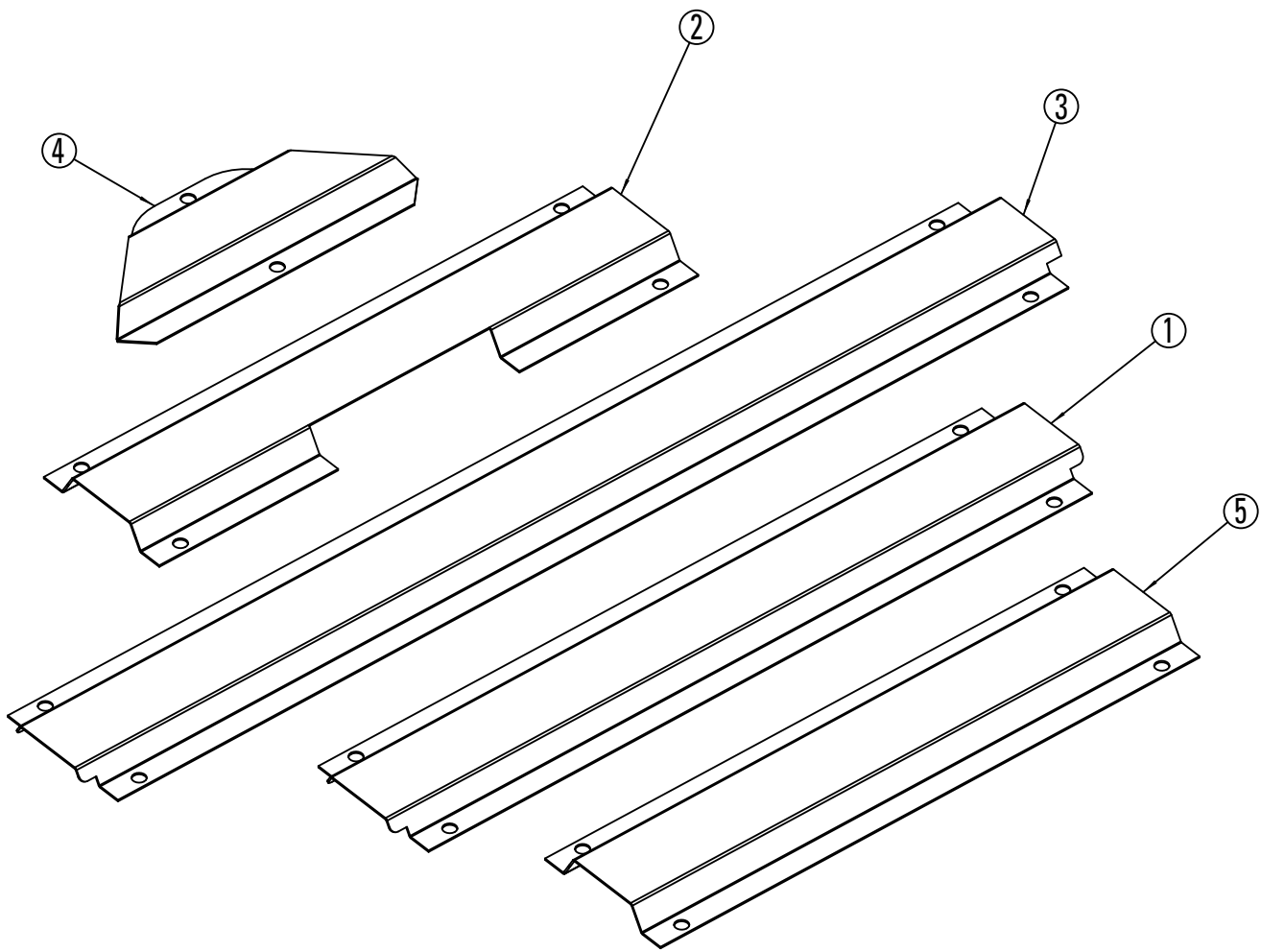

ITEM	QDE	Nº DA PEÇA	DESCRIÇÃO
1	2	XX130091Y	COBERTURA DA MANGUEIRA
2	2	XX130092Y	COBERTURA DA MANGUEIRA
3	2	XX130111Y	COBERTURA DA MANGUEIRA
4	1	XX130141Y	COBERTURA DA MANGUEIRA 45°
5	2	XX130156Y	COBERTURA DA MANGUEIRA

Observações

Observações

Observações

Vehicle Service GroupSM
2700 Lanier Drive
Madison, IN 47250, USA
1-800-640-5438
www.vsgdover.com



© **Vehicle Service GroupSM**
Todos os direitos reservados. Salvo disposição
em contrário indicado, **Vehicle Service GroupSM**,
e todas as outras marcas registradas são de
propriedade da Dover Corporation e suas afiliadas.