

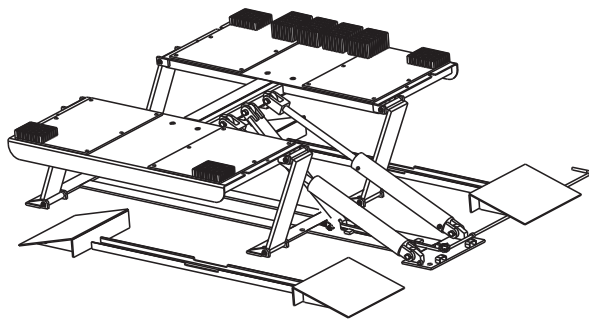

# VLXS7

**Low Rise Car Lift**  
Capacity 7000 lbs.  
(Maximum 1750 lbs. per pad)



# VLXS10

**Low Rise Car Lift**  
Capacity 10,000 lbs.  
(Maximum 2500 lbs. per pad)

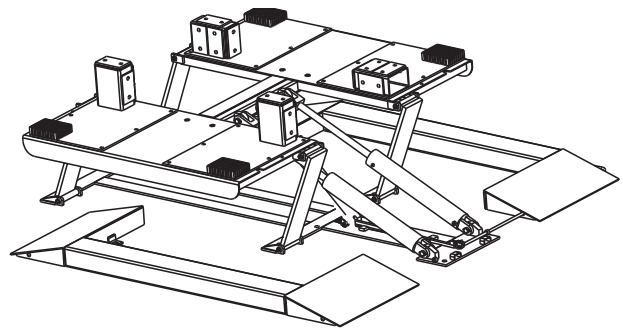

P  
A  
R  
T  
S  
  
B  
R  
E  
A  
K  
D  
O  
W  
N

**IMPORTANT:** When ordering parts or requesting service always give exact model and power unit serial number. Model number is shown on nameplate attached to power unit column. Power unit serial number is located on side of power unit.

**OWNERS RECORD**  
Complete information at right and keep in a safe place.

Date Installed \_\_\_\_\_

Installed in Bay # \_\_\_\_\_

Power Unit Serial # \_\_\_\_\_

Power Unit Model # \_\_\_\_\_

Lift Serial # \_\_\_\_\_

Lift Model # \_\_\_\_\_

**NOTE:** For replacement parts -See your nearest Rotary Parts Distributor.



**PB2-5-6**  
Rev. R 12/12/2016

1.	CYLINDER PIN	GP021420
2.	7' POWER UNIT MOUNT	GP021704
3.	1/4"-20 NYLON INSERT HEX NUT	40642
4.	1/4" FLAT WASHER	GP911405
5.	1/4"-20 HHCS X 2" LG.	GP911481
6.	5/16"-18 HEX NUT	40670
7.	5/16"-18 NYLON INSERT HEX NUT	GP911703
8.	5/16"-18 HHCS X 1-1/4 LG.	GP911751
9.	1/2" X 4-1/4" ANCHOR BOLT	GP912728
10.	3/4" X 5-1/2" ANCHOR BOLT	GP913828
11.	SPRING PIN	GP0970609
12.	ROLL PIN X 1-1/2"	GP991060
13.	ROTARY 18" DECAL	NP183
14.	CYLINDER	GP992305
15.	REAR LEG WELDMENT	GP1010100
16.	FRONT LEG WELDMENT	GP1010101
17.	BASE WELDMENT	GP1010106
18.	LEG PIN	TL-8002
19.	1/2" RETAINING RING	1010120
20.	5/8" RETAINING RING	1010121
21.	RUBBER PAD	GP1010400
22.	TOP STRUCTURE	GP1010401
23.	LOCKING LEG	GP1010500
24.	LATCH PIN	TL-8004
25.	LATCH RELEASE HANDLE	GP1010509
25.a	LATCH RELEASE HANDLE (RECESSED)	1010533
25.b	LATCH RELEASE 4-1/2" HANDLE	FC633
26.	LATCH RELEASE KEYED PIVOT	GP1010510
27.	LATCH RELEASE PIVOT	GP1010511
28.	LATCH RELEASE WELDMENT	GP1010527
29.	LATCH PIN	TL-8008

30.	RAMP WELDMENT	
	VLXS10 (Shown)	GP1010600
	VLXS7 (Not Shown)	GP1010605
31.	3" RUBBER ADAPTER (VLXS7 Only)	FJ2428
32.	CHRISTMAS TREE FASTENER	GP1010906
33.	ADAPTER ASSEMBLY (VLXS10 Only)	GP1010907
34.	RUBBER PAD (VLXS10 Only)	GP1010908
35.	HYDRAULIC KIT	GP1010909
		994450*
	17" HYDRAULIC HOSE	992217
	3/8" MJIC TEE	992502
	3/8" MJIC x 3/8" MNPT 90° ELBOW	992402
	9/16" O-RING x 3/8" MJIC 90° ELBOW	FJ7224
	117-1/2" HYDRAULIC HOSE**	992131
	264" HYDRAULIC HOSE	992224
36.	115V 60Hz POWER UNIT	P3083
	208-230V 60Hz POWER UNIT	P3084
	3Ø/208-230V/480V POWER UNIT	P3567
	1Ø/220V 50Hz POWER UNIT	P3503
37.	<a href="#">WHEEL SPOTTING DISH KIT</a>	<a href="#">FF729</a>
38.	HOSE GUARD	GP021730
39.	HOSE GUARD ANCHOR	GP991345
40.	1-1/2" RUBBER ADAPTER	FJ2427
41.	RIGHT SPACER ASSEMBLY (RECESSED MODELS ONLY)	10106107
42.	LEFT SPACER ASSEMBLY (RECESSED MODELS ONLY)	10106105
43.	CONTROL BOX ASSEMBLY (FOR 3Ø)	FA9147
44.	M8 x 10 PHMS PLATED (FOR 3Ø)	B23-8X10
45.	MOUNTING BRACKET (FOR 3Ø)	TL-6005
*Aux. Hose Kit Rear Approach		
**Hose used prior to Jan. 2008		

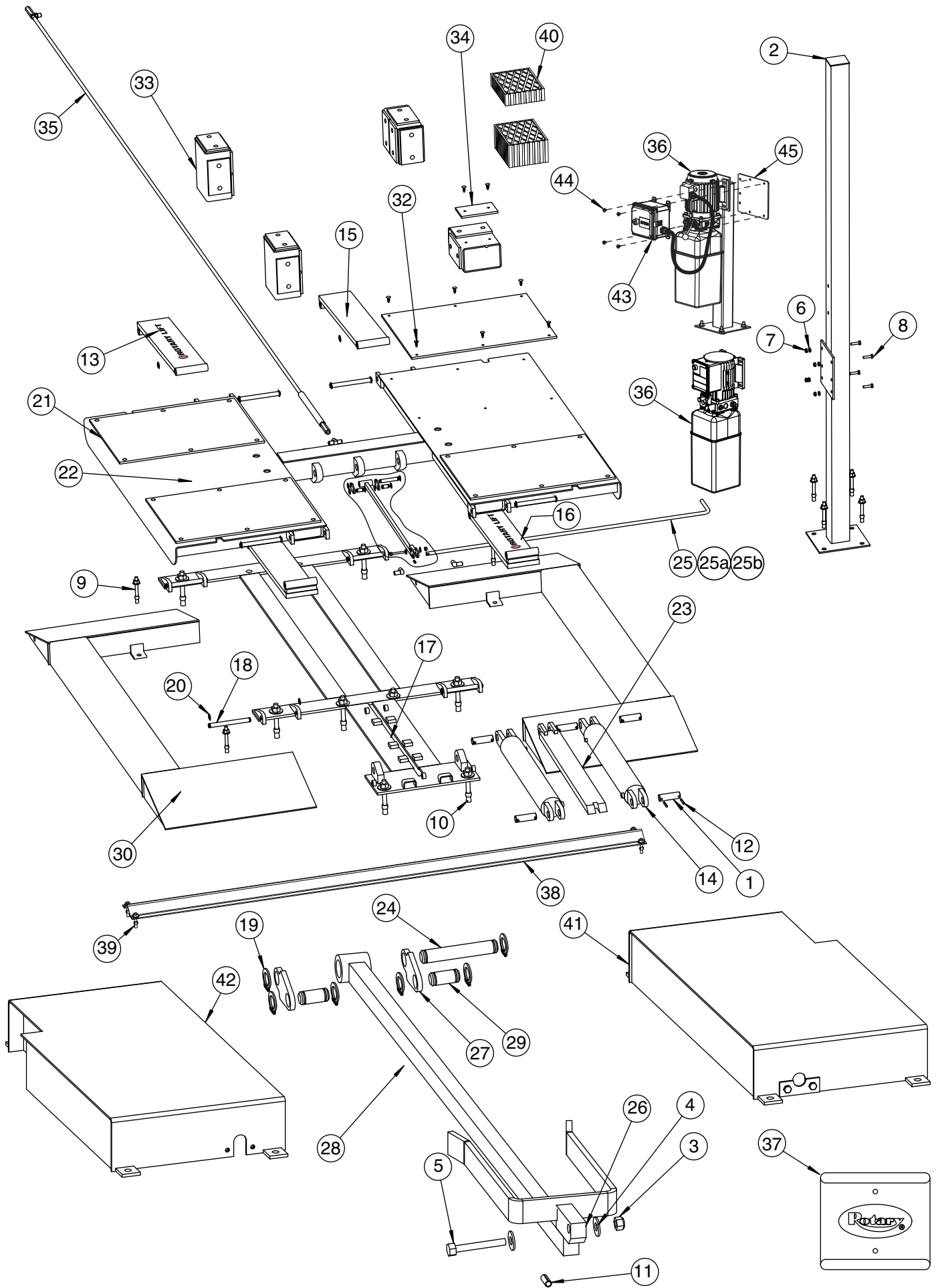

<b>Date</b>	<b>Rev.</b>	<b>Description of Change</b>
06-10-05	-	New Product Launch
09-08-05	A	Update cover to show that holes were removed from base, moved Rotary decal to rear leg (item #13), added Hose Guard (item #38 & 39), added 1-1/2" Rubber Adapters (item #40)
09-27-05	B	Added VLXS7 information
10-28-05	C	Updated power unit information
7-18-06	D	Updated part numbers
8-16-06	E	Updated power unit number and added barcode
8-13-07	F	Added Rear approach hose kit
1-2-08	G	Added breakdown of hydraulic kit - 992131 117-1/2" hose prior to 01/08
10-30-08	H	Added P3084 Power Unit
10-27-10	J	Updated Item 28 Latch Release Weldment - Revision i is always skipped.
8-11-10	K	Added spacers for recessed models
6-10-12	L	Added 3Ø option
3-26-13	M	Added 1Ø Power Unit Option
1-08-16	N	Added FC633 Latch Release Handle
9-15-16	P	Add 3Ø Control Box (FA914) and Bracket (TL-6005). B23-8x10 was 40275.
11-23-16	Q	TL-8002 was GP1010116, TL-8008 was GP1010514, TL-8004 was GP1010505, 1010120 was GP1010117, 1010120 was GP1010118.
12-12-16	R	Update images to 1010120 retaining ring.

#### Rotary World Headquarters

2700 Lanier Drive  
Madison, IN 47250, USA  
www.rotarylif.com

#### North America Contact Information

Tech. Support:  
p 800.445.5438  
f 800.578.5438  
e userlink@rotarylif.com  
Sales:  
p 800.640.5438  
f 800.578.5438  
e userlink@rotarylif.com

#### World Wide Contact Information

World Headquarters/USA: 1.812.273.1622  
Canada: 1.905.812.9920  
European Headquarters/Germany: +49.771.9233.0  
United Kingdom: +44.178.747.7711  
Australasia: +60.3.7660.0285  
Latin America / Caribbean: +54.3488.431.608  
Middle East / Northern Africa: +49.771.9233.0

#### © Vehicle Service Group<sup>SM</sup>

Printed in U.S.A., All Rights Reserved. Unless otherwise indicated, ROTARY, and all other trademarks are property of Dover Corporation and its affiliates.

